



GP

**CHICAGOLAND'S LEADER
IN REPLACEMENT WINDOW AND
DOOR HARDWARE!**

708-343-8800

www.buyblaine.com

24 hour fax: 855-898-6471

e-mail: blaineserviceandsupply@gmail.com

1644 N. Mannheim Rd., Stone Park, IL 60165

"The Place to Start When You Need a Part"

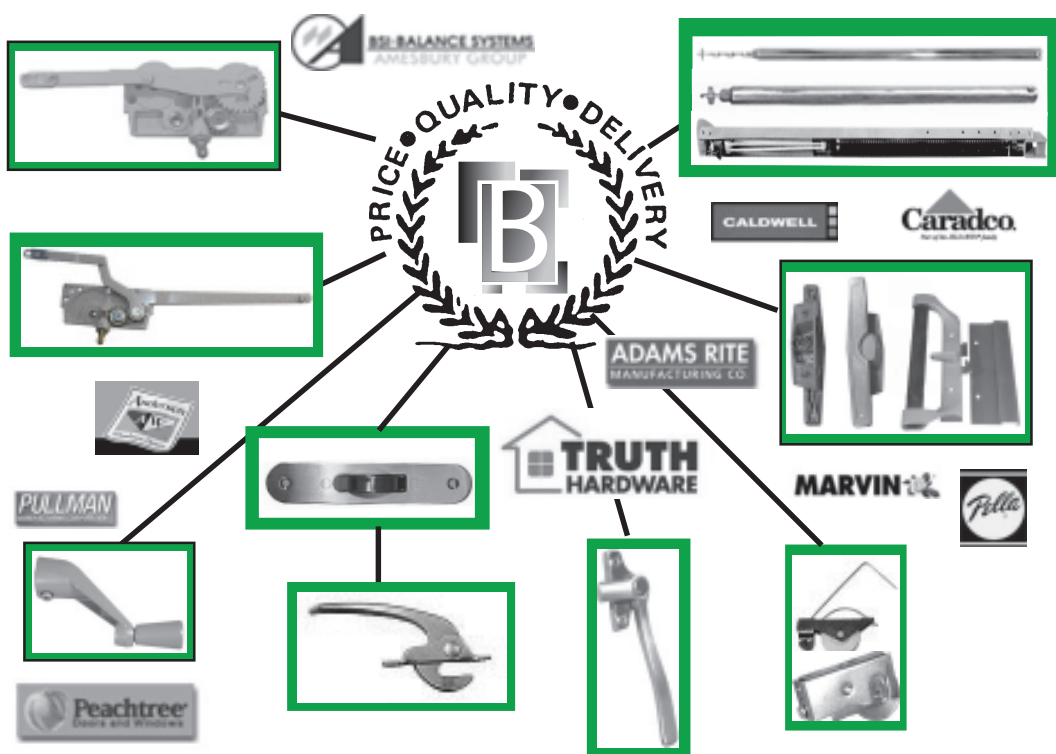

BLAINE SERVICE & SUPPLY

Andersen & Truth Hardware featured throughout this catalog. We have an extensive line of hardware available.

ORDERING INFORMATION

Ordering Information: Our catalog has been designed to make ordering as easy as possible. It is not possible to list all of the items available through Blaine. If you need items, that do not appear in our catalog, please send a sample to our Research Department at 1644 N. Mannheim Rd., Stone Park, IL 60165. To help expedite your orders, please use our part numbers, quantities required.

Delivery Status: Any delivery dates set forth by Blaine Service & Supply are estimates only and are not intended as a guarantee of date of delivery. Our pledge is for quick and efficient processing of your order. However, due to the nature of our business, stock shortages may occur from time to time. Items will remain on back-order until shipped. Blaine Service & Supply will not be liable for any delay in delivery or failure to deliver any or all of the goods in case such delay results from causes beyond our control. Order status may be obtained by calling our office at 708-343-8800.

Damages / Shortages: All material, in transit, is the property of the buyer and buyer assumes all

responsibility for filing claims and damages. **Please inspect all freight for visible damage prior to accepting. Do not accept cartons which show damage or are open. Claims for concealed damage must be made by the buyer, with the carrier, within ten (10) working days.**

Original shipping carton must be retained. Shortages must be reported to us at 708-343-8800 within ten (10) working days.

Returns: All returns / exchanges must be made within 30 days from receipt of material. Shipping charges will not be credited on returns unless authorized in writing by Customer Service. Any unauthorized returns will be refused. A restocking fee of 30% will be charged for returns when the customer ordered incorrectly. We strongly urge you to send a sample to eliminate doubt when placing orders. Special order or custom made parts are not returnable unless defective.

buyblaine.com

Terms & Conditions

Credit Policy: Terms are net 30 days for open account customers. All other orders must be pre-paid or shipped C.O.D. unless otherwise specified. Partial payment in advance may be required with an order. We accept all major credit cards.

Special Orders: Non stock parts (special orders) may require a minimum order quantity.

Stock Parts : For orders less than \$25.00, there will be a \$5.00 processing fee.

Freight: All shipments will be made by the carrier of our choice, usually U.P.S. or Post Office., unless specified otherwise. We also offer UPS Next Day

and Second Day service when requested. The customer is responsible for all shipping charges unless otherwise specified. Common carrier service is also available. An \$9.50 minimum shipping and handling charge is applied to each order. Actual shipping charges will be added when minimum is exceeded.

State Sales Tax: Customers exempt from state sales tax must provide a certificate of exemption with initial order.

Samples: Can be sent to our Research Department or e-mail photos to: blaineserviceandsupply@gmail.com

A.C. Locks.....	34 - 35
Andersen Hardware.....	7,8,11,15-16,29, 37, 50, 72
Awning / Jalousie Operators.....	9 - 14
Balances / Jambliners /Tape.....	40 - 50
Biltbest.....	14
Cam / Locking Handles.....	29 - 34
Casement Operators.....	3 - 8, 14
Corner Keys / Tilt Keys / Slidebolts.....	57 - 58
Crank Handles.....	15
Door Closers - Commercial.....	27 - 28
Drapery Hardware.....	56
Glazing Spline.....	63
Hinges (Biltbest / Cupples / Truth).....	14, 20 - 27
Horizontal Slider Hardware.....	39
Jamb Stretchers.....	45
Patio Door Guides.....	72
Patio Door Handles.....	65 - 67
Patio Door Roller Assemblies.....	67 - 72

Patio Door Track.....	64
Pella.....	7,8,15,37
Pressure Shoes & Accessories.....	55
Push Bars.....	20
Remote / Clerestory Operator.....	17
Sash Pulleys, Weights & Chain.....	51
Screen Hardware/Frame/Spline/Wire.....	77 - 79
Skylight Hardware.....	13,18 - 19
Spring / Transom Catches.....	35
Sweep Latches.....	36 - 38
Tilt Latches.....	52 - 54
Toilet Compartments / Grab Bars.....	73 - 76
Tracks / Channels / Guide Bars (Window).....	16
Truth.....	6, 9 - 13, 15 - 26, 29, 31, 33, 34, 36, 38-39
Venetian Blind Hardware.....	56
Vent Arms.....	27
Weatherstripping.....	64

BLAINE SERVICE & SUPPLY

CASEMENT OPERATORS

15.31.XX.051 As shown 9-1/2"
 15.31.XX.052 Opposite 9-1/2"

15.32.XX.051 As shown 13-1/2"
 15.32.XX.052 Opposite 13-1/2"

15.39.XX.051 As shown 6"
 15.39.XX.052 Opposite 6"

15.56.XX.051 As shown 7-1/2"
 15.56.XX.052 Opposite 7-1/2"



Order track no. 30473 track for 15.31 and order 30150 track for 15.32, sold separately.

Handle sold separately. Order no. 10579

Mounting screws included

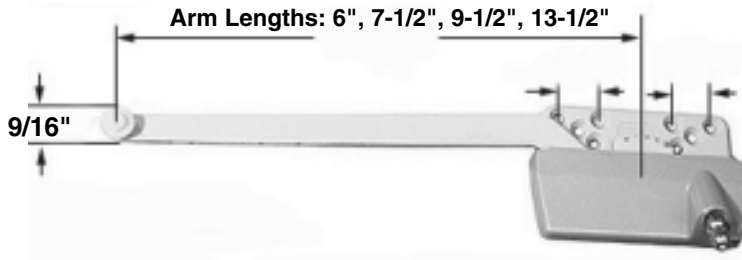

Specify arm length

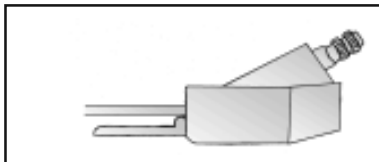

Flat Arm, Side View
Open Position

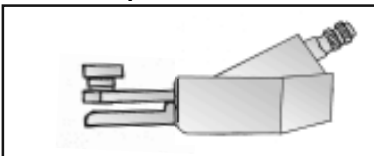

Flat Arm, Side View
Closed Position

Note:
 Bronzes are painted with a metallic finish.

Please specify color.

Please send sample for positive identification

Blaine Part No.	Hand	Arm Length	Color
15.39.29.052	R	6"	Gold
15.39.29.051	L	6"	Gold
15.39.32.052	R	6"	White
15.39.32.051	L	6"	White
15.39.23.052	R	6"	Chestnut Brz
15.39.23.051	L	6"	Chestnut Brz
15.56.24.052	R	7-1/2"	Beige
15.56.24.051	L	7-1/2"	Beige
15.56.22.052	R	7-1/2"	Clay
15.56.22.051	L	7-1/2"	Clay
15.56.32.052	R	7-1/2"	White
15.56.32.051	L	7-1/2"	White
15.56.03.052	R	7-1/2"	Bronze
15.56.03.051	L	7-1/2"	Bronze
15.31.29.052	R	9-1/2"	Gold
15.31.29.051	L	9-1/2"	Gold
15.31.24.052	R	9-1/2"	Beige
15.31.24.051	L	9-1/2"	Beige
15.31.22.052	R	9-1/2"	Clay
15.31.22.051	L	9-1/2"	Clay
15.31.32.052	R	9-1/2"	White
15.31.32.051	L	9-1/2"	White
15.31.03.052	R	9-1/2"	Bronze
15.31.03.051	L	9-1/2"	Bronze
15.32.29.052	R	13-1/2"	Gold
15.32.29.051	L	13-1/2"	Gold
15.32.22.052	R	13-1/2"	Clay
15.32.22.051	L	13-1/2"	Clay
15.32.32.052	R	13-1/2"	White
15.32.32.051	L	13-1/2"	White
15.32.03.052	R	13-1/2"	Bronze
15.32.03.051	L	13-1/2"	Bronze

BLAINE SERVICE & SUPPLY

CASEMENT OPERATORS

ENTRYGARD DUAL ARM OPERATOR

15.10.00.002 as shown
15.10.00.001 opposite

15.16.00.002 as shown
15.16.00.001 opposite

15.14.00.002 as shown
15.14.00.001 opposite

15.15.00.002 as shown
15.15.00.001 opposite

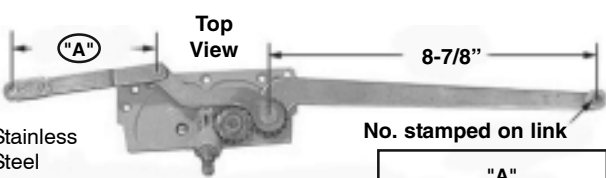

Top View 8-7/8"

Stainless Steel

No. stamped on link

"A"	No. Stamped On Link
2-3/8" - 15.15.00	20748
3-5/16"- 15.16.00	20755
3-15/16" - 15.10.00 15.14.00	20810 or 20544

Link Offset (UP) Top Clip

Side View

Please send a sample for accurate identification

Sold Separately:
10579 Handle
10339 (LH) Bracket or
10340 (RH) Bracket
30473 Track
10341 Cover

Other "A" Sizes also available. Refer to number stamped on link.

*Other dimensions available. Please Inquire

15.34.XX.053 As shown 9-1/2"
15.34.XX.054 Opposite 9-1/2"

15.35.XX.053 As shown 13-1/2"
15.35.XX.054 Opposite 13-1/2"

Casement Operator Offset Arm
1/8" Offset (Raised) Arm

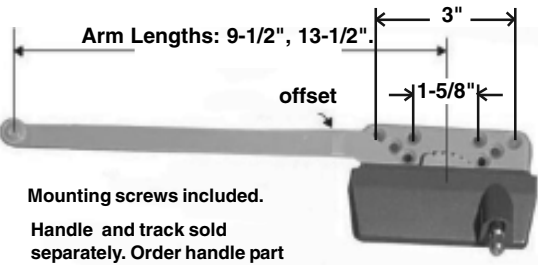

Arm Lengths: 9-1/2", 13-1/2"

offset 1-5/8"

3"

Truth Part No.	Hand	Arm Length	Color
15.34.29.054	R	9-1/2"	Gold
15.34.29.053	L	9-1/2"	Gold
15.34.32.054	R	9-1/2"	White
15.34.32.053	L	9-1/2"	White
15.34.03.054	R	9-1/2"	Bronze
15.34.03.053	L	9-1/2"	Bronze
15.35.29.054	R	13-1/2"	Gold
15.35.29.053	L	13-1/2"	Gold
15.35.03.054	R	13-1/2"	Bronze
15.35.03.053	L	13-1/2"	Bronze

Mounting screws included.
Handle and track sold separately. Order handle part number 10579 and 30473 track

11" arm unavailable. Order 9-1/2" arm.

Offset (raised arm), Side View Closed Position

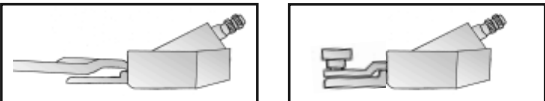

Order track no. 30473 track for no. 15.34 and order track no. 30150 for no. 15.35, sold separately.

15.11.00.001 As Shown Dyad Arm Operator
15.11.00.002 Opposite

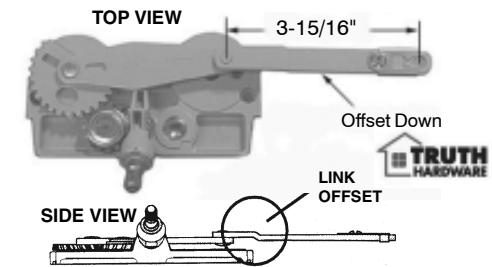

TOP VIEW 3-15/16"

Offset Down

LINK OFFSET

SIDE VIEW

10341 cover sold separately.

No. 10579.XX crank handle sold separately.

Bracket For End of Link Sold Separately
Order 12511.92 bracket for 15.11.00.002 operator.
For 15.11.00.001 operator, order 12510.92 bracket. As Shown

15.18.XX.052 As Shown
15.18.XX.051 Opposite

15.66.XX.052 As Shown
15.66.XX.051 Opposite

15.67.XX.052 As Shown
15.67.XX.051 Opposite

Colors available include Bronze or white painted finish. The color code is the 5th & 6th digit of the part number

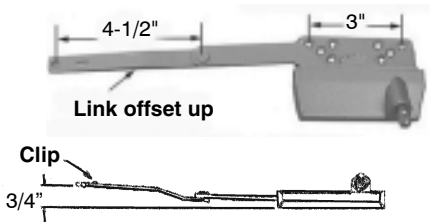

4-1/2"

3"

Link offset up

Clip 3/4"

10579.XX crank handle sold separately.

Sold Separately:
10681 Bracket for operator shown
10680 Opposite
03030-10-L/R Hinges
10579 Handle

**Snap stud attachment on 15.18 model

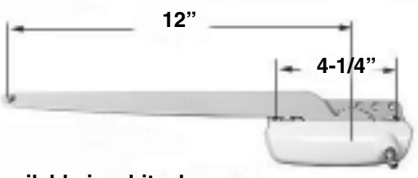
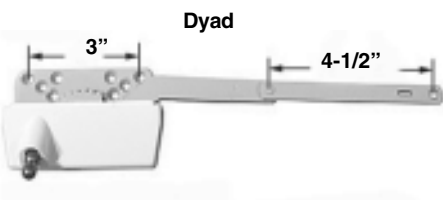
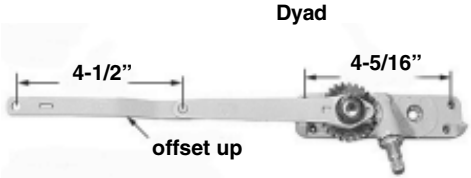
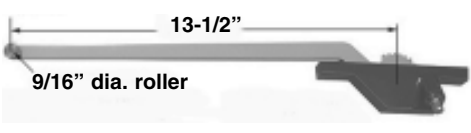
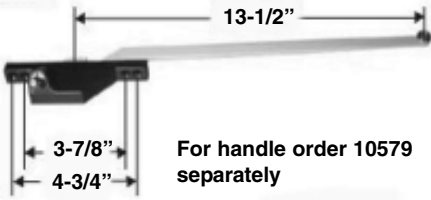
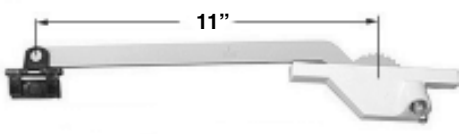
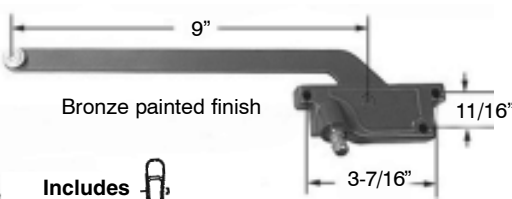
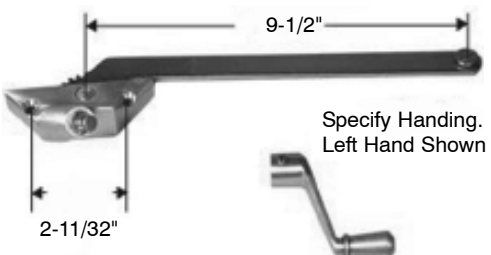

BLAINE SERVICE & SUPPLY

CASEMENT OPERATORS

<p>52.01.XX.011 As Shown 52.01.XX.012 Opposite</p>  <p>Available in white, bronze or brushed copper nickel</p> <p>For handle order 10579 separately</p>	<p>15.30.XX.051 As Shown 15.30.XX.052 Opposite</p>  <p>Available in coppertone or white</p> <p>For handle order 10579 separately</p>
<p>15.72.00.002 As Shown 15.72.00.001 Opposite</p>  <p>For handle order 10579 separately</p>	<p>23.02.XX.002 As Shown 23.02.XX.001 Opposite</p>  <p>Sold separately: 10579 handle 30175 track 03030-10-L/R Hinges 24.25 Locking Handle 21088 Keeper</p> <p>Rear mount screw holes</p> <p>For front mount, order 23.03-see below</p>
<p>23.03.XX.001 As Shown 23.03.XX.002 Opposite</p>  <p>For handle order 10579 separately</p>	<p>23.77.XX.001 As Shown 23.77.XX.002 Opposite</p>  <p>For handle order 10579 separately</p> <p>For 9" arm, order 23.04</p>
<p>00021</p> <p>Specify Handing. Right hand shown.</p>  <p>Bronze painted finish</p> <p>Includes Crank Handle</p>	<p>00026</p>  <p>Specify Handing. Left Hand Shown</p> <p>Replacement for Hope's Operator Red Bronze Housing</p> <p>Sold with #00308 Crank Handle. Order #00126 Track separately.</p>

BLAINE SERVICE & SUPPLY

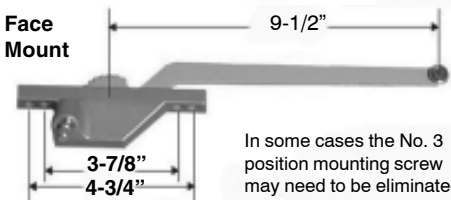
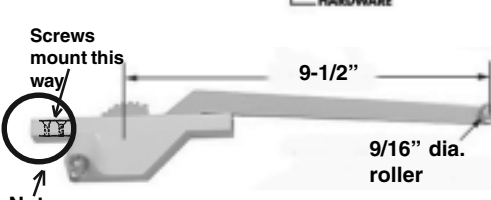
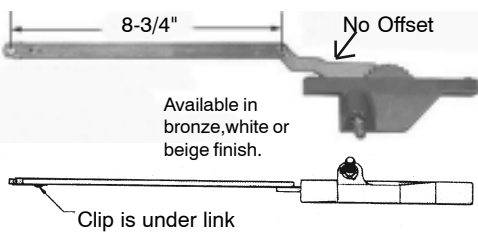
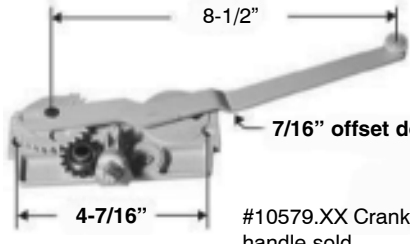
CASEMENT OPERATORS

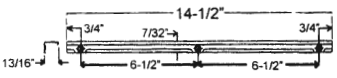
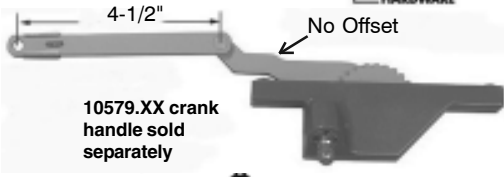
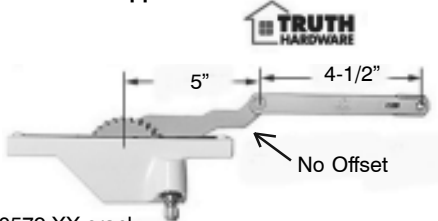
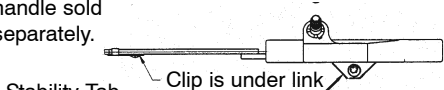
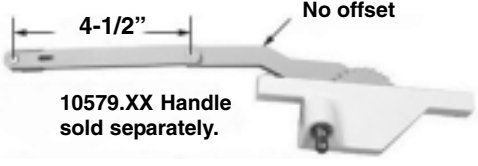
<p>23.01.XX.001 As Shown Face Mount 23.01.XX.002 Opposite</p>  <p>Face Mount</p> <p>In some cases the No. 3 position mounting screw may need to be eliminated or ground down in length due to interference in the full closing position of the arm. Another alternative would be to grind a notch in the arm to clear the screw end.</p> <p>#10579 Crank Handle sold separately.</p> <p>Available in aluminum, bronze, chestnut bronze or white.</p>	<p>23.00.XX.001 As Shown Rear Mount 23.00.XX.002 Opposite</p>  <p>Screws mount this way</p> <p>Note: Rear Mount</p> <p>Available in bronze, aluminum, chestnut bronze or white.</p> <p>10579 crank handle sold separately.</p>
<p>23.49.XX.001 As Shown Dyad Operator 23.49.XX.002 Opposite</p>  <p>#10579.XX Crank Handle Sold Separately.</p> <p>Available in bronze, white or beige finish.</p> <p>Clip is under link</p>	<p>15.94.00.002 as shown Entrygard Single Arm Operator 15.94.00.001 opposite</p>  <p>10341 cover sold separately.</p> <p>#10579.XX Crank handle sold separately.</p>
<p>50.00.XX.012 As Shown 50.00.XX.011 Opposite</p> <p>Maxim Dual Arm Casement Operator</p>  <p>For link stud bracket, order 12511</p>  <p>Sold separately: 12510 Bracket or 12511 Bracket 11576 Track 11454 Crank Handle</p> <p>11576 maxim track sold separately</p>	<p>23.46.XX.001 As shown 23.46.XX.002 Opposite</p>  <p>10579.XX crank handle sold separately</p> <p>Clip is under link</p> <p>Stability tab available on Blaine part no. 23.59</p> <p>Available in clay, bronze or white</p>
<p>23.59.XX.002 As Shown Dyad Operator 23.59.XX.001 Opposite</p>  <p>10579.XX crank handle sold separately.</p>  <p>Stability Tab</p> <p>Clip is under link</p> <p>Available in white, coppertone or beige.</p>	<p>23.54.XX.001 As shown Dyad Operator 23.54.XX.002 Opposite</p>  <p>10579.XX Handle sold separately.</p> <p>Available in clay or white.</p>







BLAINE SERVICE & SUPPLY

CASEMENT OPERATORS

<p>00017</p> <p style="text-align: center;">*Specify 6", 9", 10" or 11" arm</p> <p>*Arm Length</p> <p>Specify Handing. Right Hand Shown</p> <p>Includes crank handle</p>	<p style="text-align: center;">Custom Manufactured</p> <p>Call for finishes & pricing</p> <p>A. Arm Length: 6", 9", 10", 11" B. Arm Thickness: Specify 1/8" or 3/16" C. Standard Housing Thickness: 5/8" D. Select Type of Guide Required. Guide "A", "B" or "C"</p> <p>Guide A Guide B Guide C</p>
<p>00020-9" Arm Specify Handing. Right Hand Shown 00015-8" Arm</p> <p>Specify 8" or 9"</p> <p>Includes crank handle</p> <p>All available in aluminum or bronze painted finish</p>	<p>00011</p> <p>Includes crank handle</p> <p>Specify Handing. Right Hand Shown</p> <p style="text-align: right;">Bronze painted finish</p>
<p>00007 Non Handed Zinc Plated Steel*</p> <p>Escutcheon</p> <p>#130</p> <p>#367</p> <p>*other finishes available</p> <p>No. 00367 Crank Handle and No. 00130 Track Included</p>	<p>08458</p> <p>6-1/4"</p> <p>5"</p> <p>6"</p> <p>9/16"*</p> <p>*Older style may measure 3/4"</p> <p>Specify Handing. Right Hand Shown</p> <p style="text-align: right;">Zinc Plated Steel</p> <p>Crank Handle And Cover Sold Separately. Order No. 327 Crank Handle And No. 8459 Cover.</p>
<p>00058</p> <p>3-7/8"</p> <p>*9-1/4" or 10-1/4"</p> <p>Specify Handing Left Hand Shown</p> <p>*Arm measured from gear center to shoe rivet center.</p> <p>00058-2 Crank Handle sold separately No. 00058-Channel Track sold separately.</p>	<p>02073-9" Bronze Painted Finish 02073-11"</p> <p>9" or 11"</p> <p>1-1/2" 1-1/2"</p> <p>3-1/8"</p> <p>Offset-down</p> <p>Crank handle, shown at right, sold separately. Order 000975-1-038</p> <p>Specify Handing. Right Hand Shown</p>

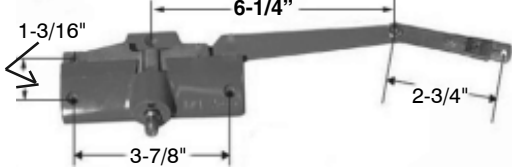
BLAINE SERVICE & SUPPLY

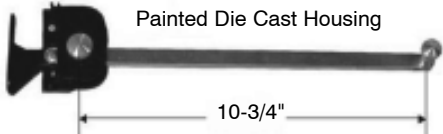
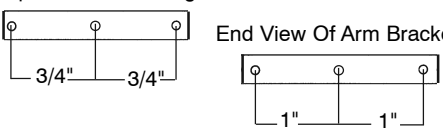
CASEMENT OPERATORS

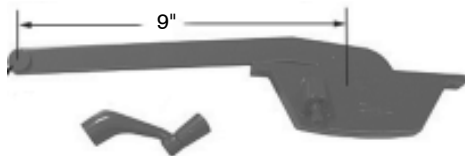
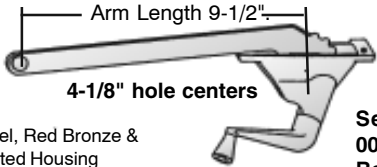
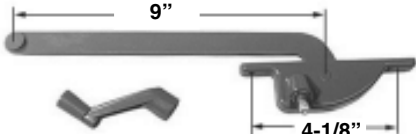
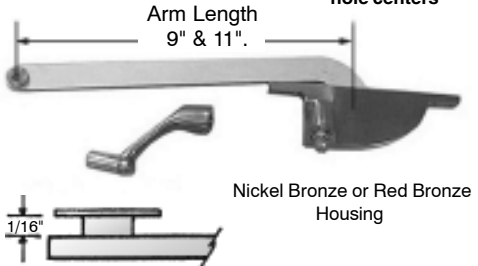
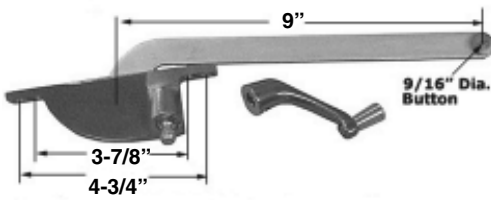
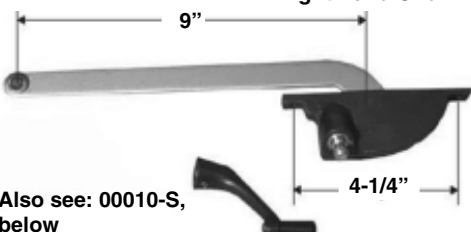
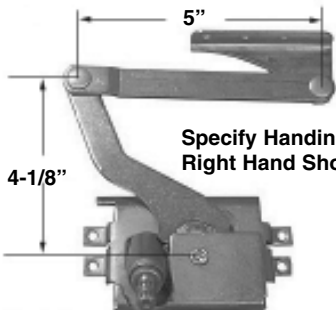
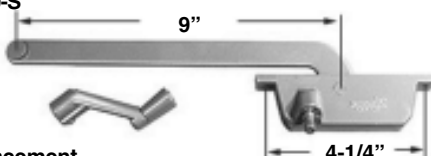
<p>10002 </p> <p>10002-1 bracket sold separately </p>  <p>58-2 Crank Handle Sold Separately Specify Handing. Right Hand Shown</p> <p>Clay Painted Finish</p>	<p>00013 </p> <p>Specify Handing. Right Hand Shown May require No. 00157 bracket to install</p> <p>Painted Die Cast Housing</p>  <p>Top View Of Housing End View Of Arm Bracket</p> 
<p>00024 </p>  <p>4-1/4" & 5-1/4" hole centers Right Hand Shown #00301 Crank Handle. Order #00126 Track separately.</p> <p>Painted Die Cast Housing Arm length 9".</p>	<p>00025 Replacement for Hopes Specify Handing. Right Hand Shown</p>  <p>Nickel, Red Bronze & Painted Housing See 00025-S, Below</p> <p>00025-S</p> 
<p>01238</p> <p>Specify Handing. Right Hand Shown 3-7/8" & 4-3/4" hole centers</p>  <p>Nickel Bronze or Red Bronze Housing</p>	<p>08453</p> <p>Specify Handing. Left Hand Shown</p> 
<p>00010 Fenestra Specify Handing. Right Hand Shown</p>  <p>Also see: 00010-S, below</p>	<p>10451 Pella</p>  <p>Specify Handing. Right Hand Shown</p>
<p>00010-S</p>  <p>Replacement</p>	<p>Order 000327 crank handle separately</p>

BLAINE SERVICE & SUPPLY

AWNING / JALOUSIE OPERATORS

22.10 Front Mount
22.19 Rear Mount

Aluminum & Vinyl Window
Awning Operator



Blaine Part No.	Arm Length	Color
22.10.01.102	24"	Aluminum
22.10.22.102	24"	Clay
22.10.32.103	24"	White
22.10.23.104	24"	Chestnut Brz.
22.10.03.102	24"	Bronze
* 22.19.32.001*	24"	White

*

***Note:**
RM models have rear threaded holes for rear mounting.

Track No. 30169 - 27-3/4" length

11.43.00.001 20-1-8" (A)
11.44.00.001 28-3/4" (A)

*

Number **10341** Cover sold separately.

Number **10579** crank handle sold separately.
Order handle color to match the cover.

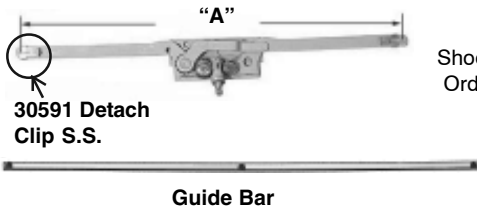

Shoes sold separately.
Order number **10005**



31641	Guide Bar
10005	Shoe Studs
10341.XX	Cover
10579.XX	Handle
31642	Guide Bar
30591	Detach Clips S.S.

Guide bar sold separately. Order number **31641.92 (22-3/4")** or **31642.92 (30-3/4")**.

22.21

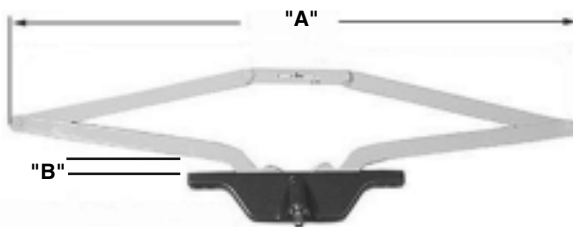

Rear Mount Dimension
(Inside holes on front mount 6-1/8" c/c)

10579 Crank Handle
Sold separately

Rear Mount (2 Holes)
or
Front Mount (4 Holes)

*Order **20008 Sash Hook**
separately

**Scissors Arm
Operator For Awning
Windows**

Operator Part No.	"A"	Mounting	Stabilizing Tab	"B" Arm Clearance
22.21	21-1/2"	Front	Order Part No. 11481	1/4"
22.22	21-1/2"			11/32"
22.23	16"			11/32"
22.27	21-1/2"	Rear		1/4"
22.28	21-1/2"			11/32"
22.29	16"			11/32"

BLAINE SERVICE & SUPPLY

OPERATOR COVERS, AWNING / JALOUSIE OPERATORS



Operator Cover

Covers

Color	Plastic	Color	Metal
Beige	10341.24	Beige	_____
Bronze	10341.03	Bronze	11328.03
Chestnut Brz	10341.23	Chestnut Brz	11328.23
Clay	10341.22	Clay	_____
Coppertone	10341.08	Coppertone	_____
Gold	10341.29	Gold	_____
White	10341.32	White	11328.32
Black	_____	Black	11328.02

10.10 20-1/2"
10.14 13-1/4"

20008 Hook
2-5/8" Uses one hook

Specify 13-1/4" or 20-1/2"

*C = 1"
C = 3/4"
E = 1/2"
F = 3/8"

Trim Sill Gap *

*Measure the distance from the bottom of the mounting plate to the base (see drawing above). Order the operator by the letter designation that corresponds to the measured distance.

10.11.29.004 Gold
10.11.03.005 Brown

2-5/8" 20008 Hook
Uses two hooks

Arm Length: 22-3/8"

*Trim Sill Gap

If Your Trim Sill Gap Measures:
1" order c
C = 3/4" order
E = 1/2" order
F = 3/8" order

*Measure the distance from the bottom of the mounting plate to the base (see drawing above). Order the operator by the letter designation that corresponds to the measured distance.

11.10.29.001 Gold 20-13/16"
11.10.03.001 Brown 20-13/16"

Wood Window Awning Operator

20-13/16"

TRUTH HARDWARE

11.12 15-5/16"
11.30 11-3/8"

#10579.XX crank handle sold separately.

11.14.29.001 Gold
11.14.32.001 White
11.14.03.001 Brown

TRUTH HARDWARE

2-5/8" 20008 Hook
Uses two hooks

24-7/8"

Wood Window Awning Operator

Order 10579.XX crank handle separately

11.16.XX.001

Clip

Shoe Stud 10005 sold separately. (2) required.

24-3/4"

Gold or white finish

26-3/4"

10579.XX sold separately.

Guide Bar 30568 sold separately.

01001

Peachtree

3-5/8"





7/8"

2-7/8"

Order crank handle separately: 01001-1-060

BLAINE SERVICE & SUPPLY

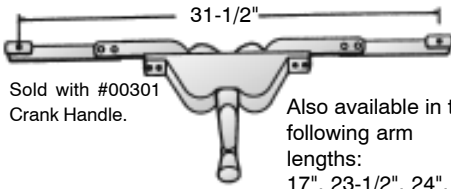
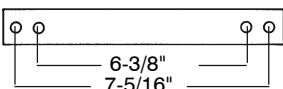
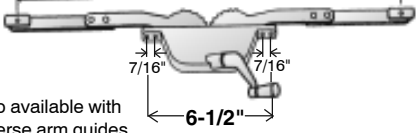
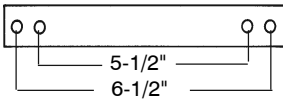
AWNING / JALOUSIE OPERATORS

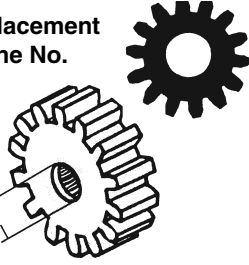
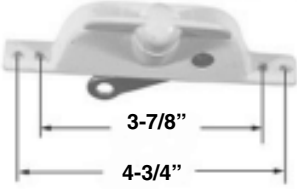
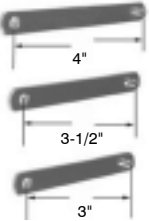
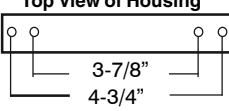
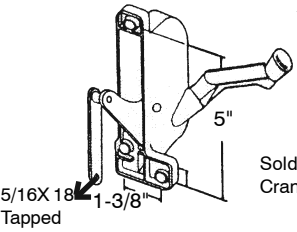
<p>51.00.32.011 Maxim Awning Operator</p> <p>White Finish</p>  <p>11454.XX Crank handle sold separately.</p>  <p>11577.92 Track and slider assembly sold separately.</p>	<p>01285* *Long - 34" Short - 24-7/8"</p>  <p>*Specify</p> <p>Bronze painted finish</p> <p>*Please specify long or short arms when ordering</p> <p>00975-1 crank handle sold separately</p> <p>Rods sold separately: Long rods: order 01285-Rod Short rods: 01285-short-rod</p>
<p>00005</p> <p>Standard Size</p>  <p>Sold with #00301 Crank Handle.</p> <p>Also available in the following arm lengths: 17", 23-1/2", 24", 27"</p> <p>TOP VIEW OF HOUSING</p> 	<p>00036</p> <p>Available in 24-1/2", 25-1/2", 27-3/4", 33", 39" Arm Lengths</p>  <p>Also available with reverse arm guides (on back of arms). Same guides as standard no. 36.</p> <p>Order: 00036-REV-27-3/4 00036-REV-33 00036-REV-39</p> <p>TOP VIEW OF HOUSING</p> 
<p>02020 Crestline</p> <p>Extra 00014 Tooth Gears Also Available. Order 00738. Covers no longer available.</p>  <p>No. 00361 Gold Crank Handle Included</p> <p>Custom Manufactured</p>	<p>00738 Crestline</p> <p>00014 tooth replacement gear for Crestline No. 02020 Operator</p>  <p>Custom Manufactured</p>
<p>00800-A</p> <p>Sold as a kit</p>  <p>Universal Operator White finish or Aluminum Available</p>  <p>Top View of Housing</p> 	<p>00073-R</p> <p>Right Hand Shown</p>  <p>Sold with #00320 Crank Handle.</p>

BLAINE SERVICE & SUPPLY

AWNING / JALOUSIE OPERATORS

00077-Original unavailable. Replace with No. 00077, shown below, right.

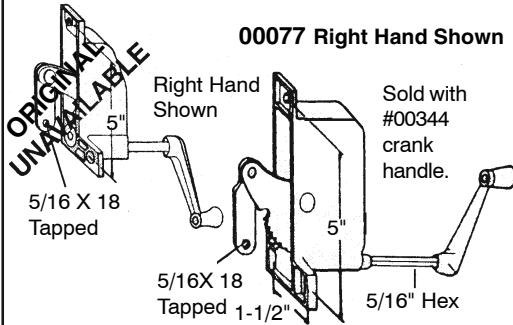

03718

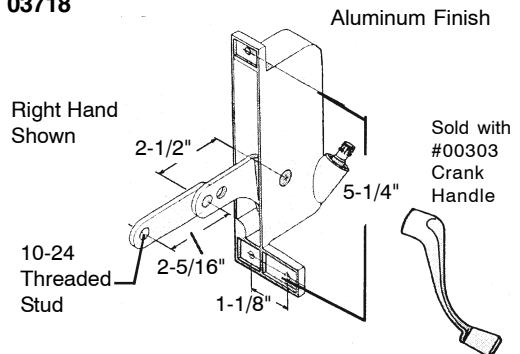

Original Unavailable Replace with No. 00095, at right

MIAMI

00095

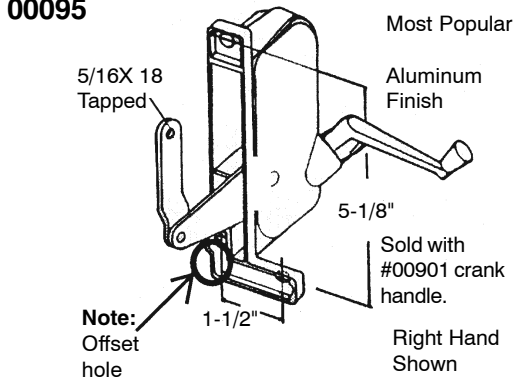
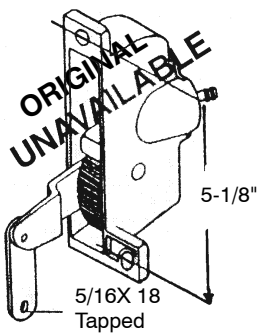

00045

Stanley

00045-1/2

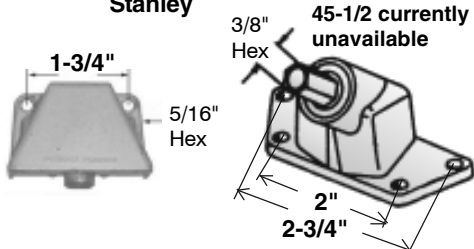

Order No. 00468-1" connector separately
 Order No. 00322 crank handle separately
 No. 00468-8" extension now unavailable.

00054

Detroit Swing Lite

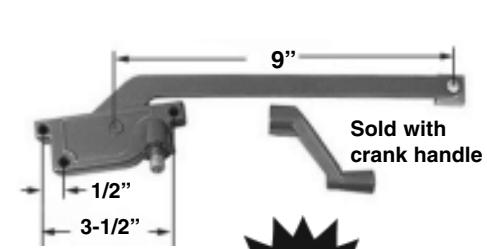

Left Hand Shown

Bronze painted finish



22.29

Rear Mount Operator

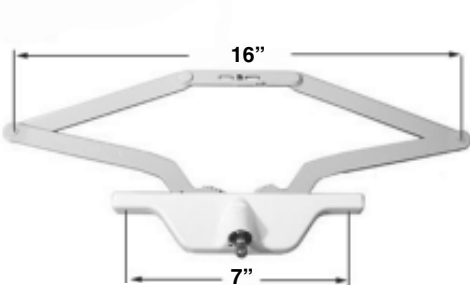

2008 Flat

Woodco

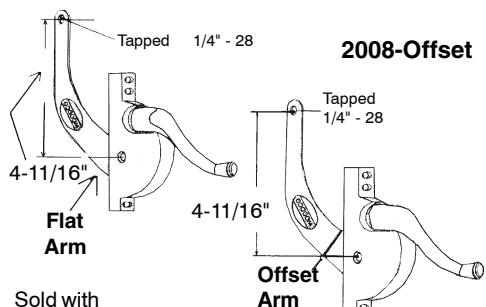





Sold with #00303 crank handle.

Sold with #00303 crank handle.

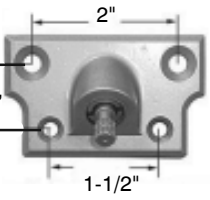
BLAINE SERVICE & SUPPLY

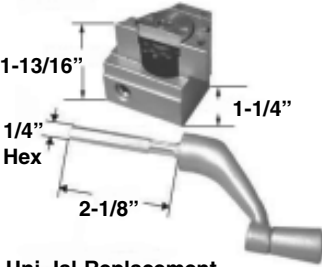
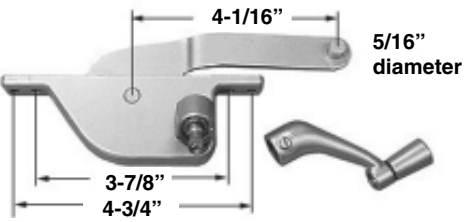
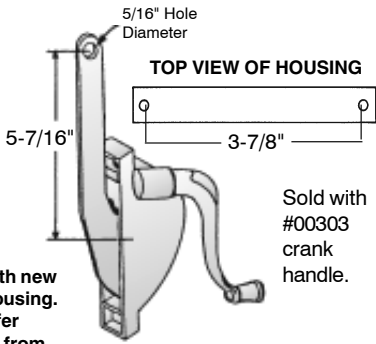
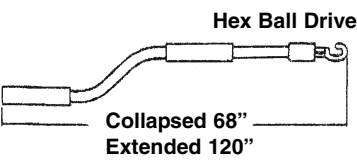
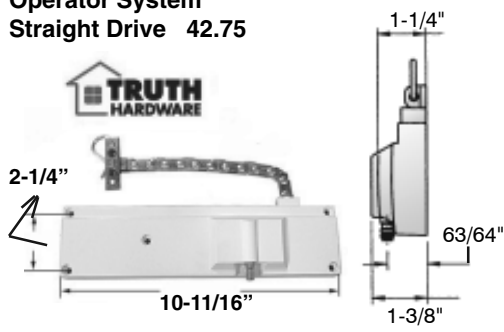
AWNING / JALOUSIE WINDOW ACCESSORIES / SKYLIGHT OPERATORS

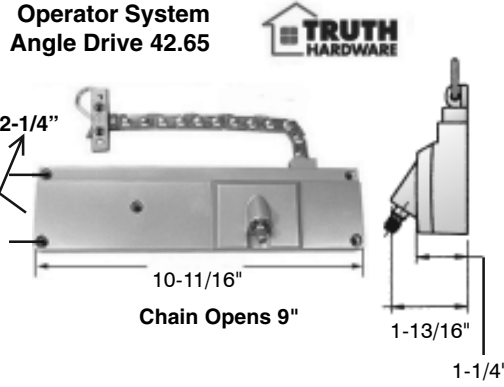
<p>00712 Ualco</p> 	<p>00726 Ualco</p> <p>Die Cast Aluminum Finish</p>  <p>00399</p>  <p>Operator for Residential Sash. Use with #00712 Gear, shown at left and #00399 Crank Handle. Both sold separately.</p>	<p>00861</p>  <p>Uni-Jal Replacement Jalousie Operator</p> <p>Right Hand Shown</p>
<p>02045 R.O.W.</p>  <p>Right Hand Shown. For Left Hand, Order 02045-L</p>	<p>02048</p>  <p>Now with new style housing. Will differ slightly from the picture</p> <p>Sold with #00303 crank handle.</p> <p>Right Hand Shown.</p>	
<p>10637 with hex ball 10638 with hook</p>  <p>Hex Ball Drive 30957 Hook End 10453</p> <p>Specify hex ball or hook end</p> <p>Recommended height range (from floor) 7' - 11' (windows) 9' - 15' (skylights)</p>	<p>Manual Skylight Operator System Straight Drive 42.75</p>  <p>TRUTH HARDWARE</p>	
<p>30662 Hex Ball Adapter</p>  <p>Specify Color</p>  <p>Includes set screw</p> <p>Available in aluminum, chestnut bronze painted or white</p> <p>Note:</p> <ol style="list-style-type: none"> Hex ball adapters fit all truth operator splines (supplied with set screws) Available in a color to match operator Maximum operational angle, when used with a hex ball pole, is 35 degrees For use with manual operators where pole operation is required 	<p>Manual Skylight Operator System Angle Drive 42.65</p>  <p>TRUTH HARDWARE</p> <p>Chain Opens 9"</p>	

BLAINE SERVICE & SUPPLY

BILTBEST OPERATORS

OLD STYLE OPERATOR BOXES - OBSOLETE

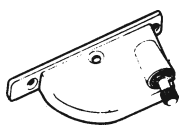

Casement & Awning



OPERATOR REPLACEMENT*

To replace operator boxes, left, it is necessary to order a complete kit with wood jamb stop, operator, track, crank handle and screws.

Please send a sample for accurate identification

KIT NUMBER	GLASS WIDTH SIZE*	SILL LENGTH
08501-N-L-087	14-5/8"	16-1/8"
08501-N-R-087	14-5/8"	16-1/8"
08501-W-L-087	19-1/8"	20-5/8"
08501-W-R-087	19-1/8"	20-5/8"
08501-XW-L-087	22"	24-7/16"
08501-XW-R-087	22"	24-7/16"
08501-XWE-L-087*	22"	24-7/16"
08501-XWE-R-087*	22"	24-7/16"

*Emergency Exit Model

CASEMENT REPAIR KIT

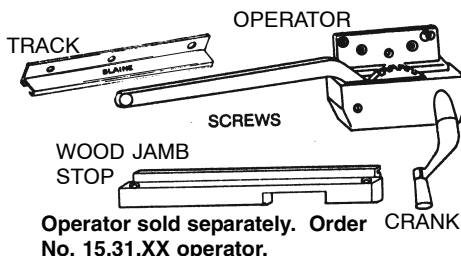

Original locking handle #08410 cannot be replaced. However, in many cases, it can be repaired. Please send your broken handle to our Research Department for an evaluation.

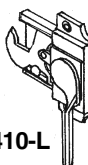

Locking Handle

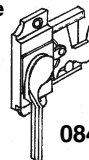

08410-L

08410-R

IMPERIAL CASEMENT HINGE REPLACEMENT FOR ALL WIDTHS

Hinge repair kits are furnished with instructions, fit all widths and are reversible to fit right or left hand vents. Sold in pairs (1 pair repairs 1 vent). Order #08500-HINGE-050.

ROTO-LOK AWNING WINDOW HARDWARE KIT**

KIT NUMBER	GLASS WIDTH X HEIGHT* SIZE	VERTICAL JAMBS	SILL LENGTH (w/ WEATHERSTRIP)
08500-A-087	19" x 14"	17-9/16" Pair	(1) 21-5/8"
08500-B-087	27" x 10"	13-9/16" Pair	(1) 29-1/4"
08500-C-087	27" x 14"	17-9/16" Pair	(1) 29-1/4"
08500-D-087	27" x 18"	21-9/16" Pair	(1) 29-1/4"
08500-E-087	27" x 22"	25-9/16" Pair	(1) 29-1/4"
08500-F-087	27" x 30"	33-9/16" Pair	(1) 29-1/4"
08500-G-087	36" x 14"	17-9/16" Pair	(1) 38-1/4"
08500-H-087	36" x 18"	21-9/16" Pair	(1) 38-1/4"
08500-I-087	36" x 22"	25-9/16" Pair	(1) 38-1/4"
08500-J-087	36" x 30"	33-9/16" Pair	(1) 38-1/4"
08500-K-087	39" x 14"	17-9/16" Pair	(1) 29-1/4"
08500-L-087	39" x 18"	21-9/16" Pair	(1) 41-1/4"
08500-M-087	39" x 22"	25-9/16" Pair	(1) 41-1/4"
08500-N-087	39" x 30"	33-9/16" Pair	(1) 41-1/4"
08500-O-087	44" x 14"	17-9/16" Pair	(1) 46-1/4"
08500-P-087	44" x 18"	21-9/16" Pair	(1) 46-1/4"
08500-Q-087	44" x 22"	25-9/16" Pair	(1) 46-1/4"
08500-R-087	44" x 30"	33-9/16" Pair	(1) 46-1/4"

**All Awning Kits come complete with screws, nylon spacers, crank handle and sash hooks.



SILL STOP

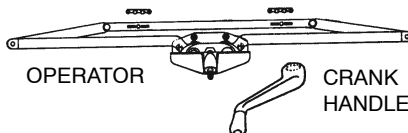

OPERATOR

CRANK HANDLE

SASH HOOK (2)

JAMB STOP (2)



BLAINE SERVICE & SUPPLY

CRANK HANDLES

11/32" Spline Diameter		Folding Handle		1"	
Color	Standard	Folding	"T"	Round	ADA
Aluminum	10579.01	11329.01	11573.01	11660.01	11403.01
Powder Black	10579.02	11329.02	11573.02	11660.02	11403.02
Bronze	10579.03	11329.03	11573.03	11660.03	11403.03
Med. Bronze	10579.05	11329.29	11573.05	11660.29	_____
Gold	10579.29	11329.29	11573.29	11660.29	11403.29
Coppertone	10579.11	11329.11	11573.11	11660.11	_____
Bright Brass	10579.13	11329.13	11573.13	11660.13	11403.13
Antique Brass	10579.14	11329.14	11573.14	11660.14	_____
Brushed Nickel	10579.19	11329.19	11573.19	11660.19	11403.19
Clay	10579.22	11329.22	11573.22	11660.22	_____
Chestnut Brnze	10579.23	11329.23	11573.23	11660.23	11403.23
Beige	10579.24	11329.24	11573.24	11660.24	11403.24
Cocoa Brown	10579.26	11329.26	11573.26	_____	_____
White	10579.32	11329.32	11573.32	11660.32	11403.32
Bright Chrome	10579.35	11329.35	11573.35	_____	_____
Off White	10579.37	11329.37	11573.37	11660.37	11403.37
Sandstone	10579.50	11329.50	11573.50	11660.50	11403.50
Oil Rubbed Brz	10579.51	11329.51	11573.51	11660.51	_____
Brushed Chrome	10579.53	11329.53	11573.53	11660.53	_____
Western Pewter	10579.55	11329.55	_____	_____	_____
Brown	10579.75	11329.75	_____	_____	_____
Bright White	10579.78	11329.78	11573.78	11660.78	_____

00975 1/4" Hex UNAVAILABLE Die Cast Bronze painted finish	00975-1 Die Cast Bronze painted finish	00058-2 3/8" dia. splined hole Diecast Clay finish
00301 Die Cast Specify Bronze or Aluminum Painted Finish	00302-5/16* 00303-3/8* Die Cast * Avail. in aluminum or bronze painted finish.	00327 Die Cast Gold or Champagne
Diecast "A" Specify color	PART # 00335-And 3/8" dia. 00335-9/32 29/32" dia. 00335-HEX 5/16" Hex 00335-7/16" 7/16" dia. 11573.XX 11/32" dia. 00335-3/8" 3/8" dia. 00335-Pella3/8" dia.	FITS Andersen Peachtree Truth Pella
00367 *Avail. 6" 8" 16" Brass Can be custom made to any length	12905.XX Flip handle and cover for Entrygard operators	00338 Also available w/ 19/64" sq. hole. Order 338-Rem Nickel Bronze, Red Bronze, Dark Statuary Bronze, Brown & Gray
00367 *Avail. 6" 8" 16" Brass Can be custom made to any length	12905.XX Flip handle and cover for Entrygard operators	12616 RH 12614 LH Truth Encore Tango Handle & Cover Specify Color

BLAINE SERVICE & SUPPLY

TRACK, GUIDE BARS & GUIDE TRACK

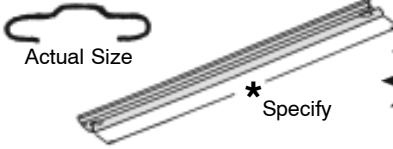
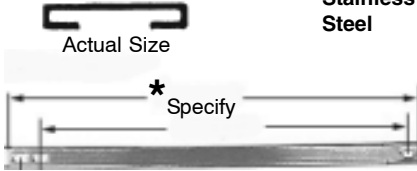
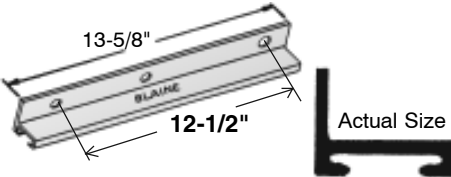
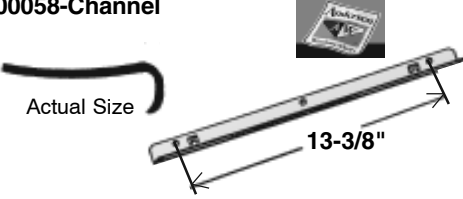
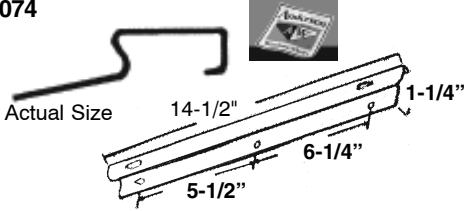
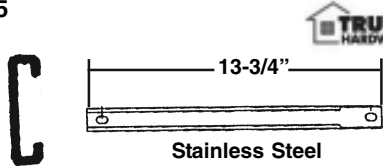
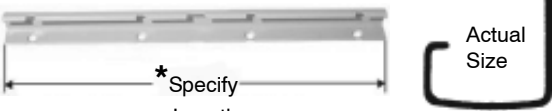
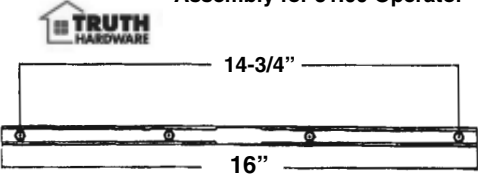
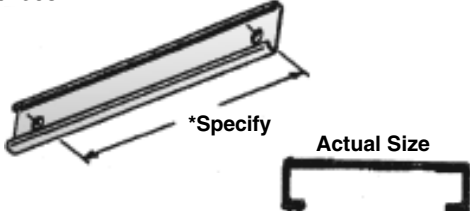
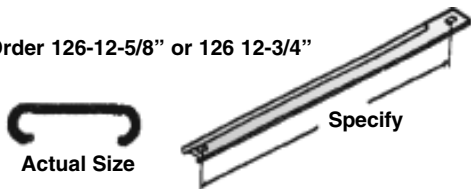
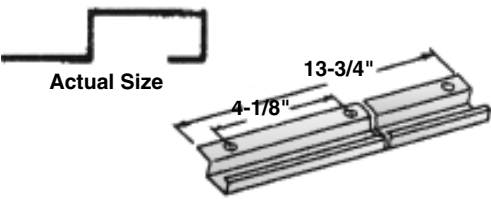
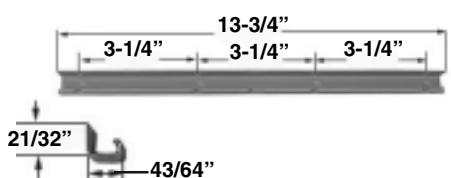
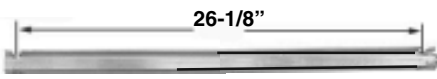
<p>00125</p>  <p>Actual Size</p> <p>* Specify</p> <p>Custom Manufactured</p> <p>*Lengths Available: 10", 11", 12-1/2" and 16-1/4".</p>	<p>00126</p>  <p>Actual Size</p> <p>* Specify</p> <p>Stainless Steel</p> <p>*Lengths Available: 12-5/8", 13-3/4" & 18".</p>
<p>00129</p> <p>Aluminum</p>  <p>13-5/8"</p> <p>12-1/2"</p> <p>Actual Size</p>	<p>00058-Channel</p>  <p>Actual Size</p> <p>13-3/8"</p>
<p>02074</p>  <p>Actual Size</p> <p>14-1/2"</p> <p>1-1/4"</p> <p>6-1/4"</p> <p>5-1/2"</p>	<p>30175</p>  <p>13-3/4"</p> <p>Stainless Steel</p> <p>Actual Size</p>
<p>30473.92 - 11-3/8" 30150.92 - 13-3/4"</p>  <p>* Specify Length</p> <p>Actual Size</p> <p>TRUTH HARDWARE</p> <p>Track for 15.10, 15.31 & 15.34 Operators 30473.92</p> <p>Track for 15.32 and , 15.35 Operators 30150.92</p>	
<p>11577</p> <p>Maxim Awning Track & Slider Assembly for 51.00 Operator</p>  <p>14-3/4"</p> <p>16"</p> <p>TRUTH HARDWARE</p>	<p>02908</p>  <p>*Specify</p> <p>Actual Size</p> <p>*Lengths stocked: 6-3/16", 7-1/16", 9-1/2" & 12". Other sizes available per customer request.</p>
<p>03033 Lengths Available: 12", 13"</p> <p>Order 126-12-5/8" or 126 12-3/4"</p>  <p>Actual Size</p> <p>Specify</p>	<p>30151.92 Track Length: 13-3/4"</p>  <p>Actual Size</p> <p>13-3/4"</p> <p>4-1/8"</p>
<p>30150</p>  <p>13-3/4"</p> <p>3-1/4"</p> <p>3-1/4"</p> <p>3-1/4"</p> <p>21/32"</p> <p>43/64"</p>	<p>30568</p>  <p>26-1/8"</p>

Remote Clerestory Operator

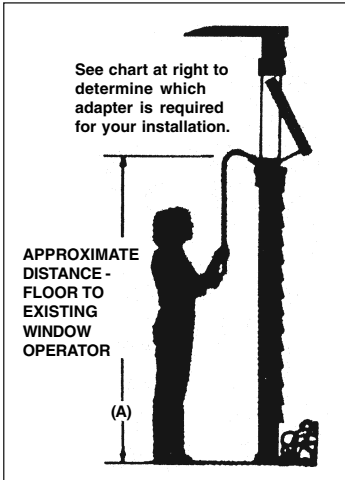

Operator Location	A	Recommended Crank Length	Part No.
Sill Mounted or Casement Style	8' - 9'	4'	02001-EX-4
	10' - 11'	5'	02001-EX-5
	12' - 14'	8'	02001-EX-8
	15' - 17'	12'	02001-EX-12



**60 Degrees
Other Degree Options
Available. Please Inquire.**

Adapter Part No.	Window and / or Hardware Brand That Adapters Fit
02001-A	Andersen
02001-P	Pella
20550	Biltbest, Caradco, Eagle, Hurd, Truth and Weathershield
02001-PT	Peachtree

ADAPTERS



NOTE: One 2001 adapter is required for each operable window.

Our adapters let you adapt our remote crank to most popular window operators. See chart for adapter part number with corresponding window manufacturer.

01236 POLE HOOK

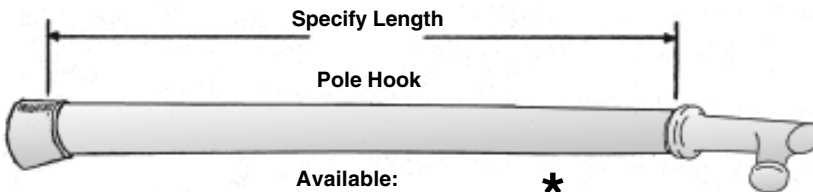

Available: *****
3', 4', 5', 6', 7', 8', 9', 10', 12', 13', 15', 16'

* 10' through 16' shipped in two sections with coupler joiner

Pole hanger #00143-029

BLAINE SERVICE & SUPPLY

Sentry II WLS Power Window/ Skylight Systems

SKYLIGHT OPERATORS

Introducing Truth's next generation of power window systems. Sentry II WLS for windows and light skylights. Based on the powerful and reliable mechanics from our previous motorization system, we've added a new digital electronics package with built in power conversion. The new Sentry II WLS system truly takes over where Truth's Sentry 2000 left off.

The new electronics package provides many new features to enhance a home's comfort and its owner's peace of mind.

- **Retrofits** onto casement and awning windows and light skylights normally operated with a hand crank manufactured by Truth Hardware (see Truth Tips). The motor system drives the same input the handle is attached to.
- **Power conversion** built right into the wall mounted control package which accepts direct connection of 110 VAC power. No more transformers to complicate and add expense to the installation.
- **Power Blind System compatible.** Centralized power window system control is now possible with Sentry II's ability to accept and control most 12 VDC power blind systems. The Sentry II's remote and wall switch can be used to control both window and blind motors for convenient, centralized control.
- **Power Protected Memory** eliminates the need to "reset" or retrain the motor after a power outage. Once the installation is complete the motor never needs further service or adjustments - even after prolonged power outages.
- **RF remote** compatibility built into all motor control packages as a standard feature. Simply order the optional remote to add new and exciting control capability for the homeowner.
- **Rain Sensor** - standard with all kits, automatically closes the window or skylight at the first sign of moisture. Corrosion resistant sensor decreases maintenance cleaning requirements and extends service life.
- **No special preparation** is required by the window or skylight manufacturer. The kits are suitable for new construction or retrofit applications. Please consult with your electrical contractor for a retrofit evaluation.
- **ETL Listed and CE Approved.** Meets all requirements for Class II installations.
- **Safety** - Automatic motor reversal has been engineered into the system which is intended to reverse the motor should an obstruction stop the window while closing. In addition, a screen interlock is provided which, when properly installed, electrically disconnects the motor when the screen is removed. These features are intended to help prevent personal injury which could result from reaching into the window area during its operation.
- **Motorized Sash Locks** are available for use with the WLS system for casement and awning windows.
- **Building Automation Systems** can easily be tied into the control electronics for virtually limitless ventilation possibilities.

SENTRY II WLS CAPACITY

When used on light skylights, Truth's Sentry II WLS is load rated at 40 lbs at the chain. This equates to a total skylight hatch weight of 80 lbs. Contact your electrical contractor for a retrofit evaluation.

When used on casement window, the Sentry II WLS is designed to work on all window systems meeting the AAMA-101 hardware load requirements (See Truth Tips).

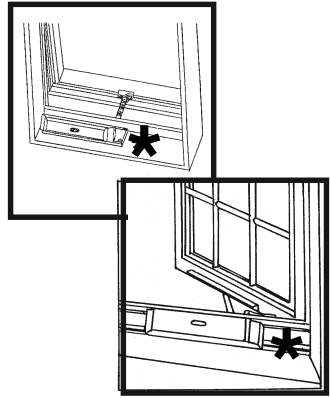

When used on awning windows, the Sentry II WLS is designed to work on awning windows with a properly sized counter-balance hinge (See Truth Tips) and operator (Consult awning operator specifications).

Sentry II power window system is rated at 50 Watts.

CONTROL OPTIONS

The Sentry II WLS kit comes with a standard wall control panel. The same control panel can also accept and control most commercially available 12 VDC mini blinds (not provided by Truth Hardware). The panel also provides feedback to the user via a status light (LED). This small LED shows when the motor is running, or if there are any problems during window or skylights operation.

The optional **RF Hand Held Remote** is available which adds even more flexibility and convenience to a home's windows or skylights.

Important:

Electrical components are generally not returnable. However, a request for return will be evaluated on a case by case basis. Please contact Customer Service to determine whether a return authorization can be provided.

BLAINE SERVICE & SUPPLY

Sentry II WLS Power Window / Skylight Systems

REMOTE FEATURES INCLUDE:

- **Infinite number** of windows and skylights can be controlled with a single remote.
- **9 Zones** or "unit codes" are available to allow units to be controlled in groups and organized to a user's needs.
- **Motorized Blinds** (supplied by others) can be controlled with the same remote.
- **Control windows and skylights** from one remote - The Sentry II HS (for large / heavy skylights) uses the same remote as the Sentry WLS for coordinated ventilation throughout the entire home or building.
- **Built in Thermostat** allows windows and skylights to open and close together, to coordinate a comfortable interior temperature. Takes advantage of true "chimney effect" cooling to reduce energy demands.
- **Rolling Code Technology** proven in garage door openers is built into every remote to provide high security and peace of mind.

WARRANTY:

The Sentry II family of products is warranted for one year against defects in materials and workmanship on all electronic and mechanical components.

Consumer Notice:

The Sentry II WLS power system must be installed by a qualified electrician.

PRODUCT APPLICATION ASSISTANCE:

If you need assistance with product configurations to meet your needs, please visit our website at www.truth.com. Under the "Technical Support" tab you will find all of the technical information needed to properly configure and specify all elements of an automated window installation, including installation instructions, pre-wiring and proper hardware requirements.

ORDERING INFORMATION:

Ordering of the new Sentry II systems is much easier than in the past. All hardware necessary for mounting the system on either a window or skylight is now included in the same kit.

Special Note: Motor covers are ordered separately to help keep your inventory costs down. Sentry II motor kit packaging includes additional space so cover can be added which allows the manufacturer to supply a complete kit to the jobsite.

WHEN APPLYING TO TRUTH OPERATORS - USE THE FOLLOWING:

Order (1) each per window:

43.51.00.005 Sentry II WLS System

12490.XX - Cover (.xx denotes finish code)

Order (1) Hand Held Remote (optional):

43.53.00.002 - Hand Held RF Remote

If you are applying the Sentry II to a **PELLA** brand window you must order the following items which include special hardware and instructions.

Order (1) each per window:

43.54.00.005 - Sentry II WLS System - Pella

12490.XX - Cover (.xx denotes finish code).

Order (1) Hand Held Remote (optional):

43.53.00.002 - Hand Held RF Remote

If you are applying the Sentry II to an **ANDERSEN** brand window with a size .350" diameter splined shaft you must order the following items which include special hardware and instructions:

43.51.00.005 - Complete Unit

32013-.365 - Complete Unit

12490.XX - Cover

43.53.00.002 - (Optional) Hand Held RF Remote

If you are applying the Sentry II to an **ANDERSEN** brand window with a size .365 dia. splined shaft you must order the following items which include special hardware and instructions:

43.51.00.005 - Complete Unit
32013-.365

12490.XX - Cover

43.53.00.002 - (Optional) Hand Held RF Remote

Finish Codes: The WLS cover is available in **02** Black, **03** Bronze, **23** Chestnut Bronze, **24** Beige, **32** White and **78** White.

TRUTH TIPS:

1. Truth Hardware does not recommend the use of Sentry II WLS on any casement window system that does not meet AAMA 101 hardware load requirements. All hardware and motor system warranties are void if the window system does not meet these guidelines.

2. Awning windows must be equipped with a properly sized counter balance hinge such as Truth Hardware's 13 series or 34 series 4-bar hinges. If an awning window is specified with butt (or continuous) hinges, a skylight operator and motor system must be used. All hardware and motor system warranties are void if these guidelines are not followed (See Tech Notes).

3. Unless otherwise specified, the Sentry II WLS power window system is designed to operate any properly sized rotary hardware and hinge system manufactured by Truth Hardware.

Use of the Sentry II WLS motor system on windows or skylights with manual hardware manufactured by companies other than Truth Hardware is **at your own risk**. For verification, look for the Truth logo / name stamped on the hinge and operator arm or consult with the window manufacturer.

4. The Sentry II WLS system is rated for use in indoor applications only.

INCLUDE TRUTH SPECS IN YOUR NEXT SKYLIGHT PROJECT:

Motorized system for skylights (not exceeding 80 lbs), awning or casement windows.

BLAINE SERVICE & SUPPLY

TRUTH / ANDERBERG HINGES AND PUSH BARS

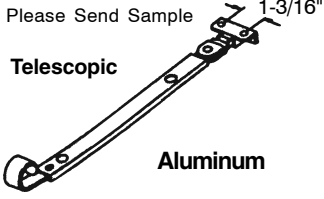
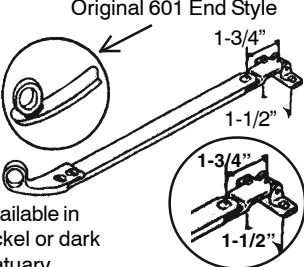
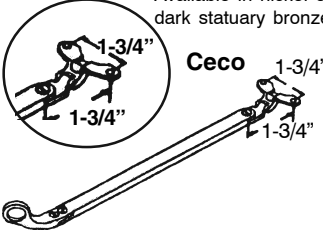
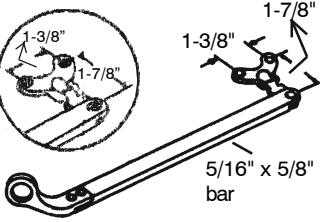
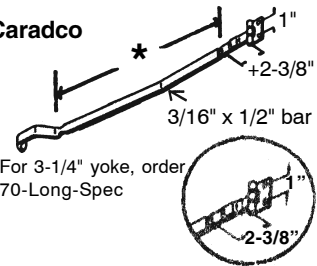
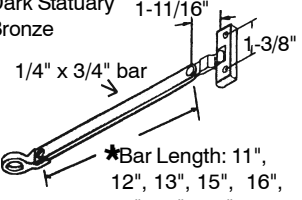
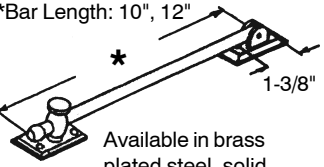
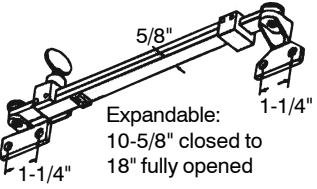
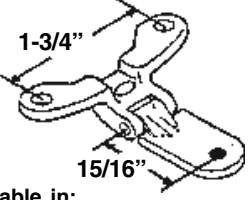
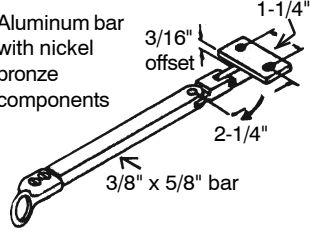
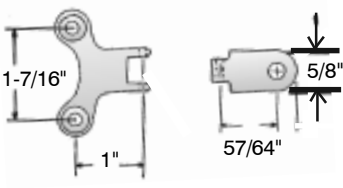
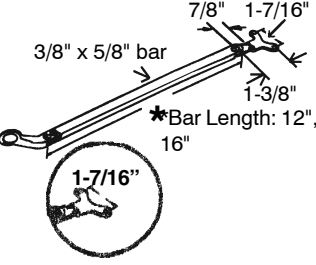
<p>12.XX Truth / Anderberg/ Superior</p> <p>More Than 20 Variations. Please Send Sample</p> <p>Telescopic</p> <p>Aluminum</p> 	<p>00601</p> <p>Original 601 End Style</p>  <p>Available in nickel or dark statuary bronze</p> <p>Bar length: 9", 11", 16".</p>	<p>00622 Bar length: 12", 16", 18"</p> <p>Available in nickel or dark statuary bronze</p> <p>Ceco</p>  <p>Truscon /RepublicSteel</p>
<p>00628 Superior Nickel Bronze</p>  <p>*Bar length: 10", 12", 16", 18" & 24"</p>	<p>00670-Short-10** Gold painted 00670-Long-13-1/4** steel</p> <p>Caradco</p>  <p>+For 3-1/4" yoke, order 670-Long-Spec</p>	<p>01627</p> <p>Dark Statuary Bronze</p>  <p>*Bar Length: 11", 12", 13", 15", 16", 17", 18", 19" & 25"</p>
<p>01631</p> <p>*Bar Length: 10", 12"</p>  <p>Available in brass plated steel, solid brass, antiqued brass or polished nickel.</p>	<p>04922</p>  <p>Expandable: 10-5/8" closed to 18" fully opened</p> <p>Solid yellow brass bars with solid red bronze components</p>	<p>00613</p>  <p>Available in: Dk statuary bronze Nickel Bronze Red Bronze</p>
<p>00627</p> <p>Aluminum bar with nickel bronze components</p>  <p>*Bar Length: 12", 14", 18"</p>	<p>01674</p> <p>Ware</p>  <p>Red bronze or nickel bronze</p>	<p>01675 Ware</p> <p>Nickel Bronze</p>  <p>*Bar Length: 12", 16"</p>

TRUTH AWNING HINGES

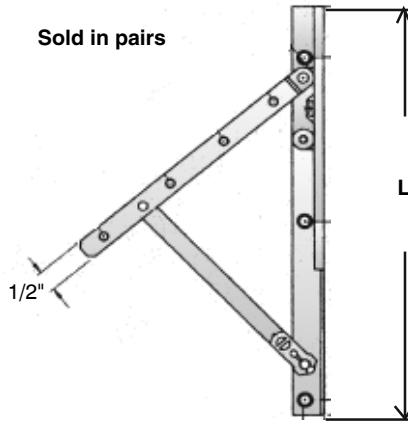

Blaine Part Number	Truth Part Number	Sash Height	Max. Sash Wt.	Hinge Track Length "L"	Material
02997-10-L/R-050	13.13.00.003 & 004	10 - 14"	7 LB	10"	Steel
02997-10-L/R-034	13.43.00.102 & 202	10 - 14"	7 LB	10"	Stainless Steel
02997-14-L/R-050	13.14.00.003 & 004	14 - 19"	20 LB	14"	Steel
02997-14-L/R-034	13.44.00.202 & 203	14 - 19"	20 LB	14"	Stainless Steel
02997-18-L/R-050	13.15.00.003 & 004	19 - 26"	38 LB	18"	Steel
02997-18-L/R-034	13.42.00.102 & 103	19 - 26"	38 LB	18"	Stainless Steel
02997-22-L/R-050	13.16.00.003 & 004	26 - 34"	50 LB	22"	Steel
02997-22-L/R-034	13.45.00.102 & 103	26 - 34"	50 LB	22"	Stainless Steel
02997-26-L/R-050	13.17.00.003 & 004	34 - 42"	61 LB	26"	Steel

TRUTH CASEMENT HINGES

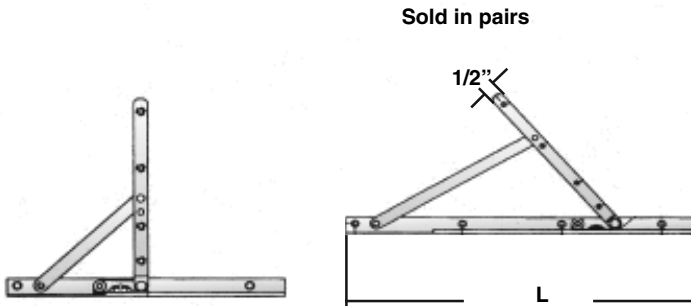

Blaine Part Number	Truth Part Number	Hinge Track Length "L"	Material
03030-10-050	14.05.00.003 & 004	10"	Steel
03030-10-034	14.80.00.503 & 504	10"	Stainless Steel
03030-14-050	14.17.00.005 & 006	14"	Steel

STANDARD DUTY 4-BAR HINGE PART NUMBER GUIDE

MATL	SIZE (IN.)	PART NUMBER	STOP	NO STOP	LOOSE RIVETS	
SS	8	34.10.00	101	102		
ST	8	34.17.00	104	103	102	105
SS	10	34.11.00	102	101		
ST	10	34.18.00	100	101		
SS	12	34.12.00	100	101		
ST	12	34.19.00	104	103		101
SS	14	34.13.00	102	101		
ST	14	34.20.00	100	101		
SS	16	34.14.00	100	101		
ST	16	34.21.00	102	101		100
SS	18	34.15.00	102	101		
ST	18	34.22.00	100	101		
SS	20	34.16.00	100	101		
ST	20	34.23.00	102	101		100

Denotes hinges without stops (maximum opening)

PART NUMBERING SYSTEM

Product No.	Model	Finish	Assembly
34	10	00	101
4-Bar Hinge	Std. Duty 8" length	No decorative finish	w/stop (hinge feature)

4-BAR HINGE APPLICATION TABLE FOR PROJECTED & AWNING HINGES (As certified to AAMA 904.1)

TRUTH PART NUMBERS		HINGE LENGTH	PROJECTED & AWNING APPLICATIONS		DEGREE OF OPENING	
STAINLESS STEEL	STEEL		VENT HEIGHT RANGE	MAXIMUM VENT WEIGHT	STD. STOP	NO STOP
34.10	34.17	8" (203.2mm)	9" (228.6mm) - 16" (406.4mm)	19 (8.6Kg.)	54°	65°
34.11	34.18	10" (254.0mm)	16" (406.4mm) - 20" (508.0mm)	23 (10.5Kg.)	55°	65°
34.12	34.19	12" (304.8mm)	20" (508.0mm) - 24" (609.6mm)	28 (12.7Kg.)	55°	65°
34.13	34.20	14" (355.6mm)	23" (584.2mm) - 28" (711.2mm)	33 (15.0Kg.)	55°	65°
34.14	34.21	16" (406.4mm)	26" (711.2mm) - 34" (863.6mm)	40 (18.2Kg.)	55°	65°
34.15	34.22	18" (457.2mm)	28" (711.2mm) - 34" (863.6mm)	40 (18.2Kg.)	55°	65°
+34.16	34.23	20" (508.0mm)	32" (812.8mm) - 34" (863.6mm)	40 (18.2Kg.)	55°	65°

+ If A.A.M.A. certification is not required the 20" (508.0mm) hinge can be used on vents up to 32" (812.8mm) high and weight up to 47 lbs. (21.4Kg.).

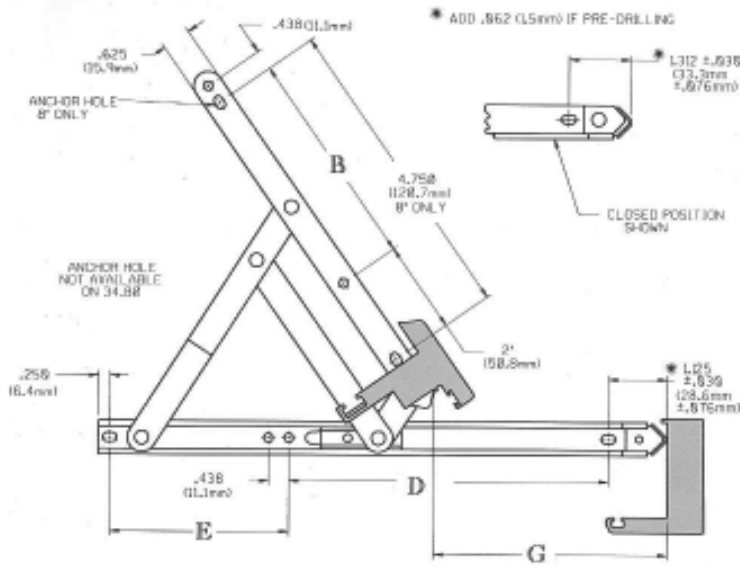

TRUTH STANDARD DUTY 4-BAR HINGE
(Anderberg 201 Series)

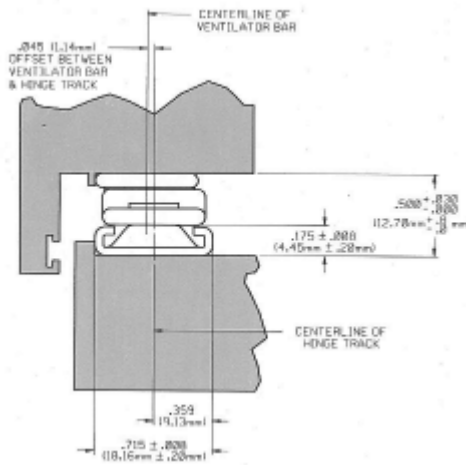

RECOMMENDED SCREWS:

STEEL: 6 - NO. 10 SLOTTED OR NO. 8 PHILLIPS, PAN HEAD SCREWS (LENGTH AND THREAD TYPE TO BE DETERMINED BY PROFILE DESIGN)

STAINLESS STEEL: 6 - NO. 10 SLOTTED OR NO. 8 PHILLIPS, PAN HEAD, STAINLESS STEEL SCREWS (LENGTH AND THREAD TYPE TO BE DETERMINED BY PROFILE DESIGN)

LOCATION OF ANCHOR HOLE FOR A NO STOP TRACK

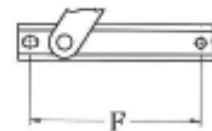

TRUTH PART NO.		HINGE LENGTH	VENTILATOR BAR B	DEGREE OF OPENING	
SS	ST			STD. STOP	NO STOP
34.10	34.17	8" (203.20mm)	N/A	54°	65°
34.11	34.18	10" (254.00mm)	3.750 (95.3mm)	55°	65°
34.12	34.19	12" (304.80mm)	4.750 (120.7mm)	55°	65°
34.13	34.20	14" (355.60mm)	5.750 (146.1mm)	55°	65°
34.14	34.21	16" (406.40mm)	6.750 (171.5mm)	55°	65°
34.15	34.22	18" (457.20mm)	7.750 (196.9mm)	55°	65°
34.16	34.23	20" (508.00mm)	8.750 (222.3mm)	55°	65°

BLAINE SERVICE & SUPPLY

TRUTH HINGES

HEAVY DUTY 4-BAR HINGE PART NUMBER GUIDE

MATL	SIZE (IN.)	PART NUMBER	STOP	NO STOP	LOOSE RIVETS	.125 SHIM	.187 SHIM	.250 SHIM	.312 SHIM	SS TRACK	SS TRACK & RIVETS	REINFORCED SUPPORT ARM	ALUMINUM HINGES ONLY						
													.125 SHIM	.250 SHIM	.350 TRACK	.385 TRACK			
SS	10	34.24.00	100	103	111 110	101	104	107	114	115									
ST	10	34.33.00	100	108		101	110	103			106	107			100	102	103	105	106
AL	10	34.41.00																	
SS	12	34.25.00	111	109	110 112	107	108	105		102									
*SS	12	34.85.00			100														
ST	12	34.34.00	106			106					101	100							
AL	12	34.42.00													104	103	102	101	
SS	14	34.26.00	100	102		101	106	110	107										
ST	14	34.35.00	100			103	101				102	106							
AL	14	34.43.00													100	101	102	103	105
SS	16	34.27.00	104	102	105	101		100											
ST	16	34.36.00	103			102					100	104							
AL	16	34.44.00													102			101	100
SS	18	34.28.00	100	104		101	105		108										
ST	18	34.37.00	100		104	103		102			101	105							
AL	18	34.45.00													100			101	
SS	20	34.29.00	107	106	101	105		103	102										
ST	20	34.38.00	107	106	101							100							
AL	20	34.46.00													103			102	101
SS	24	34.31.00	106	104		101	106						107						
ST	24	34.39.00	100	101				102											
SS	28	34.86.00	100																

Denotes hinges without stops (maximum opening)
 * Denotes hinges with a black acetal shoe.

PART NUMBERING SYSTEM

Product No.	Model	Finish	Assembly
34	24	00	100
4-Bar Hinge	Heavy Duty 10" length	No decorative finish	w/stop std. open (hinge feature)

- When an awning window is "under hinged," (i.e., when a hinge is used on a window larger than is recommended), chatter is likely to occur when operated with a Roto Gear Awning Operator (See Truth Tips in Roto Gear Awning Operator section).
- For additional Truth Tips regarding this 4-Bar Hinge please refer to the Truth Tips section of this brochure.
- Unless otherwise specified all hinges have a brass shoe.
- The standard stack height of a Heavy Duty Hinge .625" (15.9 mm). If a shim is used, the stack height will increase by the shim thickness.
- For **Heavy Duty Hinges** the maximum vent weight for side hung (casement) application is 90 lbs. (41 Kg.) on hinges with a black acetal shoe and 100 lbs. (45.5 Kg.) on hinges with a brass shoe. (See Truth Tip #1).
- Since the vent slides away from the frame when opened, only dyad type operators are compatible with Heavy Duty Hinges.

4-BAR HINGE APPLICATION TABLE FOR PROJECTED & AWNING HINGES (as certified to A.A.M.A. 904.1)

TRUTH PART NUMBERS			HINGE LENGTH	PROJECTED & AWNING APPLICATIONS		DEGREE OF OPENING	
STAINLESS STEEL	STEEL	ALUMINUM		VENT HEIGHT RANGE	MAXIMUM VENT WEIGHT	STD. STOP	NO STOP
34.24	34.33	34.41	10" (254.0mm)	12" (304.8mm) - 20" (508.0mm)	58 (26.4Kg.)	58°	77°
34.25	34.34	34.42	12" (304.8mm)	20" (508.0mm) - 25" (635.0mm)	73 (33.2Kg.)	52°	77°
34.26	34.35	34.43	14" (355.6mm)	23" (584.2mm) - 29" (736.6mm)	85 (38.6Kg.)	48°	77°
34.27	34.36	34.44	16" (406.4mm)	25" (635.0mm) - 34" (863.6mm)	99 (45.0Kg.)	48°	77°
34.28	34.37	34.45	18" (457.2mm)	32" (812.8mm) - 37" (939.8mm)	108 (49.1Kg.)	49°	77°
34.29	34.38	34.46	20" (508.0mm)	34" (863.6mm) - 40" (1016.0mm)	117 (53.2Kg.)	48°	77°
+34.31	34.39	N/A	24" (609.6mm)	40" (1016.0mm) - 44" (1117.6mm)	129 (58.6Kg.)	45°	77°
34.86	N/A	N/A	28" (711.2mm)	50" (1270.0mm) - 64" (1625.6mm)	175 (81.0Kg.)	40°	N/A

Definitions:

* **Counter-Balanced:** a pair of hinges will balance or hold open the vent/sash with no added friction at the heights and weights listed in the chart.

****Ultimate:** A pair of hinges will not balance or hold open the vent/sash without added friction at the heights and weights listed in the chart.

Special NOTE: A properly counter-balanced sash may be important to obtain other important window operating characteristics such as proper operation of a rotatory awning operator

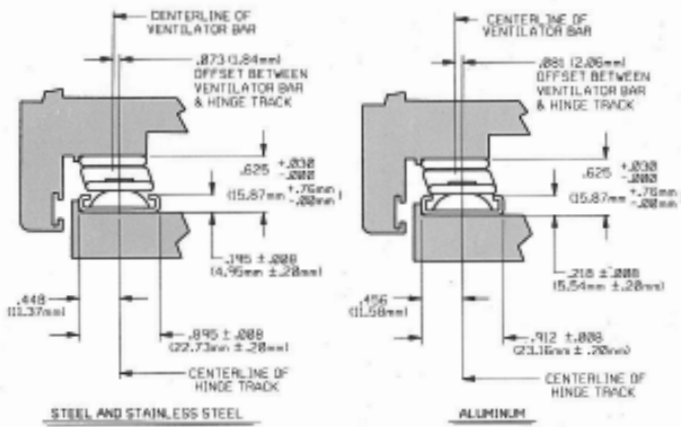
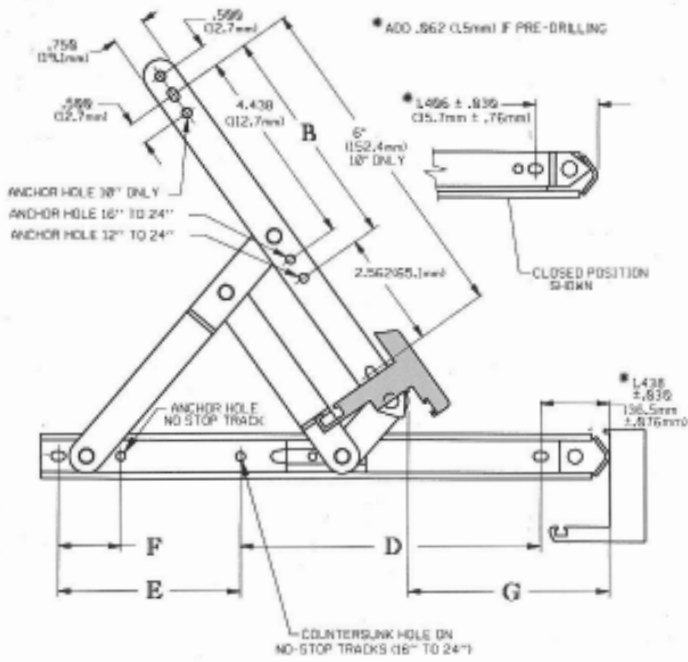

RECOMMENDED SCREWS:

STEEL: NO. 10 PHILLIPS PAN HEAD SCREWS. LENGTH AND THREAD TYPE TO BE DETERMINED BY PROFILE DESIGN. IF FOR SCREW QUANTITIES REQUIRED FOR PROPER MOUNTING SEE TABLE BELOW.

STAINLESS STEEL: NO. 10 PHILLIPS PAN HEAD STAINLESS STEEL SCREWS. LENGTH AND THREAD TYPE TO BE DETERMINED BY PROFILE DESIGN. IF FOR SCREW QUANTITIES REQUIRED FOR PROPER MOUNTING SEE TABLE BELOW.

ALUMINUM

TRUTH PART NO.			VENTILATOR BAR		DEGREE OF OPENING		SCREW QUANTITIES
SS	ST	AL	HINGE LENGTH	B	STD. STOP	NO STOP	
34.24	34.33	34.41	12" (254.00mm)	N/A	58°	77°	6
34.25	34.34	34.42	12" (304.80mm)	4.938 (125.4mm)	52°	77°	6
N/A	34.85	N/A	12" (304.80mm)	4.938 (125.4mm)	76°	N/A	6
34.26	34.35	34.43	14" (355.60mm)	5.938 (150.8mm)	48°	77°	6
34.27	34.36	34.44	16" (406.40mm)	6.938 (176.2mm)	49°	77°	7
34.28	34.37	34.45	18" (457.20mm)	7.938 (201.6mm)	49°	77°	7
34.29	34.38	34.46	20" (508.00mm)	8.938 (227.0mm)	49°	77°	7
34.31	34.39	N/A	24" (609.60mm)	10.938 (277.8mm)	45°	77°	7
34.86	N/A	N/A	28" (711.200mm)	12.938 (335.0mm)	40°	N/A	7

BLAINE SERVICE & SUPPLY

TRUTH LIMIT DEVICES / BUTT HINGES

Truth Standard Duty Limit Device With Key Release

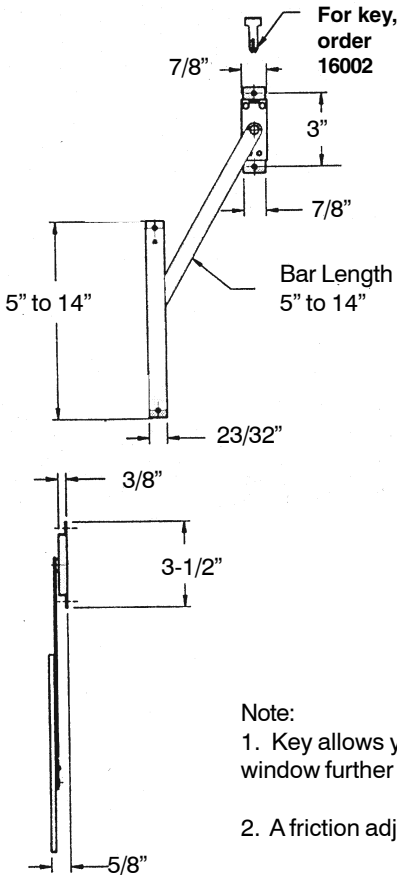

Limit Device With Key Release Feature

Part Number	Track Length	Bar Length
37.26.00.200	5"	5"
37.27.00.200	6"	6"
37.28.00.200	7"	7"
37.29.00.200	8"	8"
37.30.00.200	9"	9"
37.31.00.200	10"	8"
37.31.00.201	10"	10"
37.32.00.200	11"	11"
37.33.00.202	12"	12"
37.34.00.201	14"	14"

Note:

1. Key allows you to detach support arm to open the window further for maintenance.
2. A friction adjustment screw is provided in the shoe.

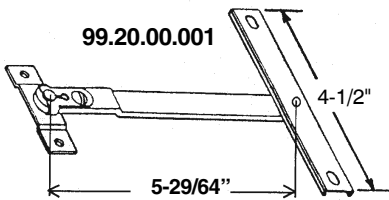

Limit Devices:

When properly installed and operated, the Limit Device will help prevent damage to casement and awning windows under high winds in high-rise applications. Two different methods of disconnecting the Limit Device from the sash for cleaning purposes - either by inserting a key, or by operating the detach clip.

Truth Loose Butt Hinge 29.10.00.102 Left Hand Pair 29.10.00.103 Right Hand Pair

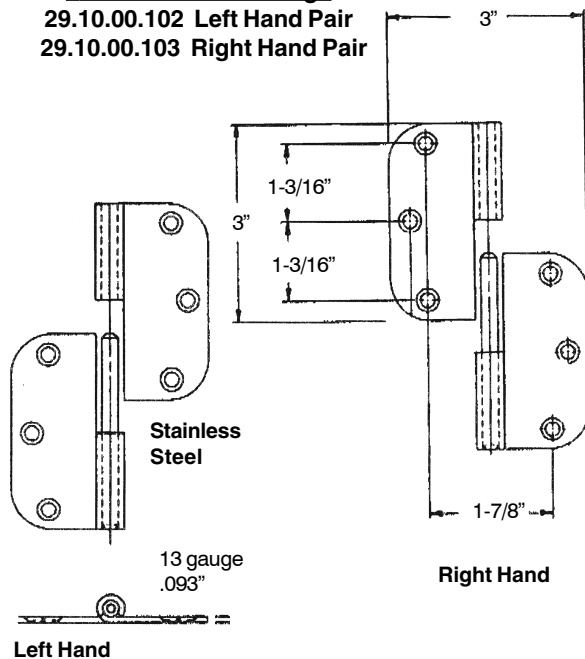

Used On Cupples Windows

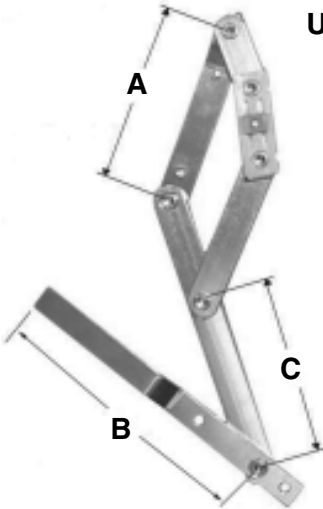



Blaine Part Number	A	B	C
00700-6	4-3/16"	5-9/32"	4"
00700-8	4-3/16"	6-13/32"	4"
00700-10	7-3/16"	7-25/32"	7"
00700-12	7-3/16"	11-9/32"	7"

Vent Arms - Custom Made To Size

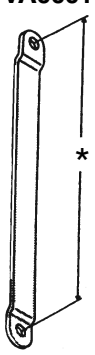

VA0001



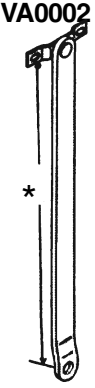

VA0002

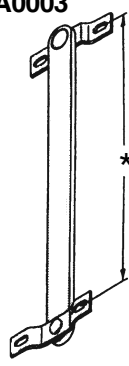

VA0003

**Specify
Aluminum
or Steel**

*Please send a sample or request a worksheet from Customer Service.

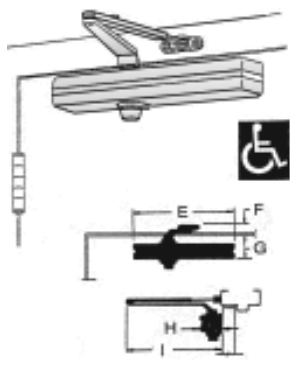

Features:

- One 1461 Super stock can be mounted three different ways.
 1. Hinge Face
 2. Top Jamb
 3. Stop face (parallel arm)
- 1461 Series is non-handed, non-sized with spring power adjustable from size 2 through 6
- Delayed action optional.
- Heavy-duty forged main arm.
- Cast Iron cylinder.
- Full rack and pinion hydraulic action.
- Joints in arm and shoe adapt to uneven trim.
- Non-critical regulating screws are tamper resistant.
- 10 year warranty ; UL Listings

Part No. DC0017-1461-037		
Exterior or Vestible Door	Interior Doors	Reg. Arm
2'0" (600 MM) through 4'0" (1200 MM)	2'0" (600 MM) through 5'0" (1500 MM)	1461

E	F	G	H	I
12-1/4"	1-1/8"	2-11/16"	2-3/8"	11-1/4"

COMMERCIAL DOOR CLOSERS

MADE IN THE U.S.A.

FULL 10 YEAR FACTORY WARRANTY

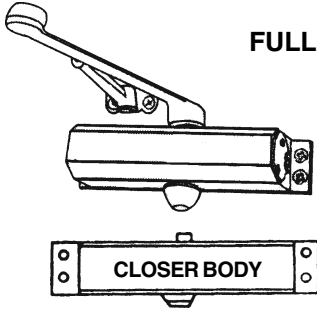

Blaine Door Closers provide narrow styling and installation versatility. They are ideal for use with aluminum doors and frames, yet they make an attractive installation on wood or metal doors.

Blaine Door Closers are non handed and, for standard non-hold open or hold open applications, can be mounted on regular and top jamb installations. An optional mounting bracket is available for parallel installations.

ADA Closer, shown above, available. Please call for details.

FEATURES

Standard

- Parallel Arm Bracket
- Non-Handed
- Aluminum Alloy Shell
- Adjustable Closing Speed
- Adjustable Latching Speed
- Non-Hold Open
- Adjustable Power Shoe
- Adjustable Back Check

Optional

- Adjustable Delayed Action Closing (ADA)
- Hold Open Arm

U.L. & U.L.C. Listing

All Blaine door closers, with non-hold open arms or hold open arms, are listed by Underwriters Laboratories under their continuing re-inspection programs.

SIZE SELECTION CHART

MODEL	MAXIMUM DOOR WIDTH	
	INTERIOR	EXTERIOR
DC0002	2'8"	--
DC0003	3'0"	2'6"
DC0004	3'8"	3'0"
DC0004 Econ	3'6"	3'0"
DC0005	4'0"	3'6"
DC0008	5'0"	4'6"

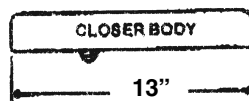
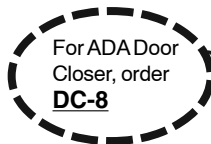
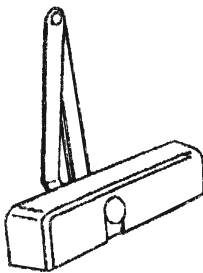

COMPARISON CHART

FUNCTION	Blaine	Yale	Norton	Dorma	LCN
Standard	DC Series	50	1600	600	---
Backcheck	DC Series-BC	50BC	1600BC	610	1070
Parallel Arm	DC Series-PA	50	1600PA	600PA	1070P
Hold Open	DC Series-HO	150	1600H	600FHO	1070H





BLAINE SERVICE & SUPPLY

LOCKING HANDLES

<p>16.16.XX</p> <p>TRUTH HARDWARE</p> <p>LH Shown</p> <p>2-3/8" hole centers</p> <p>2-9/16" x 3" housing</p> <p>1-3/8"</p> <p>3/8"</p> <p>1-3/4"</p> <p>35/64"</p> <p>Sold w/keeper no.20034 (non handed)</p> <p>Cannot be used with tie bar for tandem application</p>	<p>16.18.XX.210 16.19.XX.210*</p> <p>TRUTH HARDWARE</p> <p>2"</p> <p>*16.19 is tie bar compatible</p> <p>Non handed Low profile</p> <p>16.18 & 16.19 sold w/std kpr no. 31344</p>	<p>16.52.XX.300 16.53.XX.300*-upper</p> <p>TRUTH HARDWARE</p> <p>2-1/4"</p> <p>2-5/16"</p> <p>Non-handed Home Gard Primary Sash Lock (Lower)</p> <p>*16.53 is tie bar compatible</p> <p>Keeper sold separately: 40902 LH 40903 RH</p> <p>*Non Handed Home Gard Secondary (Only) Sash Lock (Upper w/o lever)</p>
<p>00101</p> <p>FENESTRA</p> <p>Right Hand Shown</p> <p>9/16"</p> <p>2-5/8"</p> <p>Handle offsets to the right for right hand.</p> <p>Stamped Steel Gray or Brown finish</p>	<p>00109-New Right Hand Shown</p> <p>FENESTRA</p> <p>2-1/16"</p> <p>2-1/2"</p> <p>15/16"</p> <p>1-7/16"</p> <p>2-5/16"</p> <p>3/4"</p> <p>00109-Old</p> <p>Left Hand</p> <p>Specify painted bronze or painted silver satin.</p>	<p>00135</p> <p>FENESTRA</p> <p>1/2"</p> <p>2-5/8"</p> <p>Nickel or med. statuary bronze</p> <p>Right Hand Shown</p> <p>Handle offsets to the right for right hand.</p>
<p>00430</p> <p>Non-Handed</p> <p>11/32"</p> <p>2-3/8"</p> <p>Nickel or Red Bronze</p>	<p>04979</p> <p>3/8"</p> <p>2-5/16"</p> <p>Left Hand Shown</p> <p>Nickel Bronze or Red Bronze</p>	<p>09498</p> <p>Nickel or med. statuary bronze</p> <p>1/2"</p> <p>2-3/8"</p> <p>Left Hand Shown</p>
<p>24.13.XX.202 Lower</p> <p>TRUTH HARDWARE</p> <p>1/2"</p> <p>2-3/8"</p> <p>Several finishes available</p> <p>Tie Bar Connection</p> <p>For 3/8" gap order: 24.12.XX.200 Lower 24.12.XX.201 Upper</p>	<p>24.13.XX.203 Upper</p> <p>Several finishes available</p> <p>1/2"</p> <p>2-3/8"</p> <p>Tie Bar Connection</p>	<p>24.25.XX.300</p> <p>Bronze painted, coppertone or white</p> <p>7/8"</p> <p>2-1/2"</p> <p>Multi Point Locking System</p>

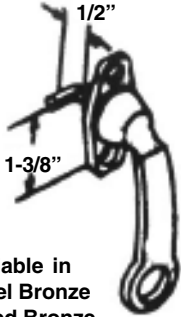
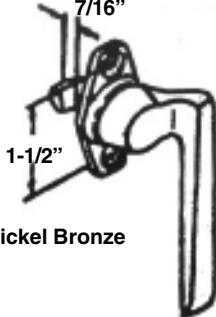
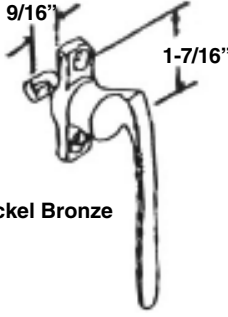
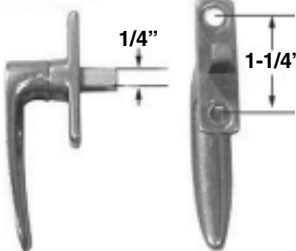
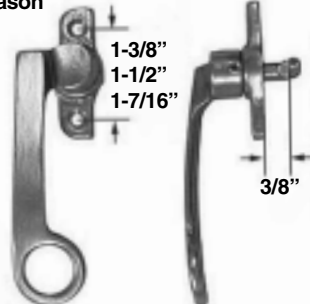

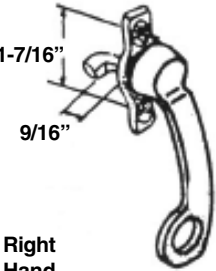
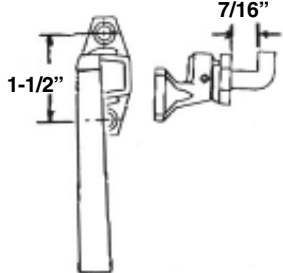
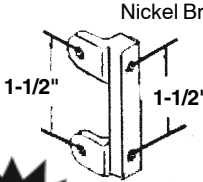
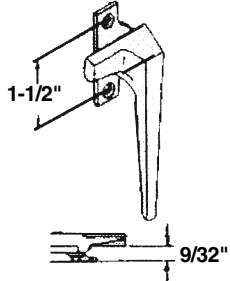
BLAINE SERVICE & SUPPLY

I.G.W. / PROJECT OUT CAM HANDLES

<p>04840 Right Hand Shown</p>  <p>Available in Nickel Bronze or Red Bronze</p>	<p>04928 Winco</p>  <p>Nickel Bronze</p> <p>Right Hand Shown</p>	<p>08366</p>  <p>Nickel Bronze</p> <p>Right Hand Shown</p>	
<p>10194</p> 	<p>12501 Mason Left Hand Shown</p>  <p>For non-pole ring handle, order 12500 For 1/2" lug, non pole ring, order 12510</p>	<p>12510 Mason</p>  <p>1/2" Lug Gap</p> <p>For ring handle, order 12511</p> <p>Right Hand Shown</p> <p>Available in red bronze, nickel bronze or dark statuary bronze powder coat</p>	
<p>21337 Nickel Bronze</p>  <p>Right Hand Shown</p>	<p>27.19</p>  <p>Left Hand Shown</p>	<p>PROJECT OUT CAM HANDLES</p>	
<p>00192</p>  <p>Nickel Bronze</p> <p>Project Out</p> <p>Angle Adapter</p> <p>Custom Manufactured</p>	<p>00191</p>  <p>Right Hand Shown</p>		
			<p>00201 Right Hand Shown</p>  <p>21/32" nose reach</p> <p>1-1/2"</p> <p>5/16" from back of base to underside of nose</p> <p>Available in Nickel Bronze and Red Bronze</p>



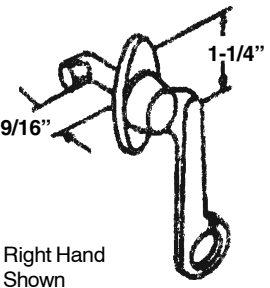
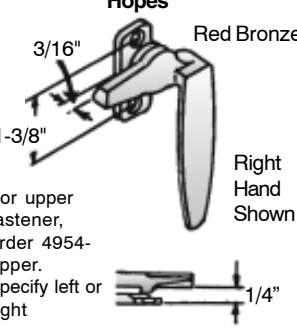
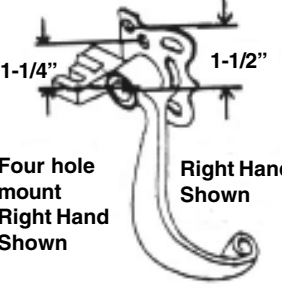
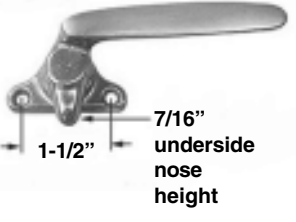
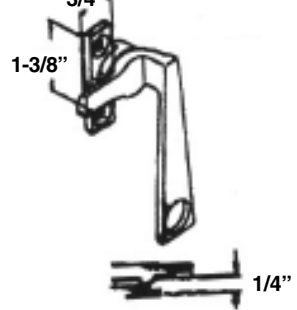
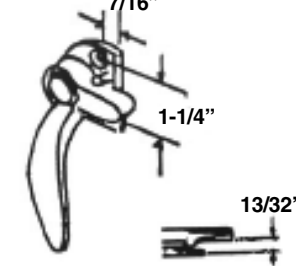
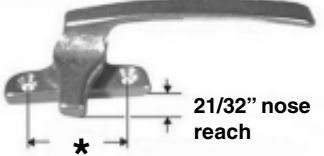
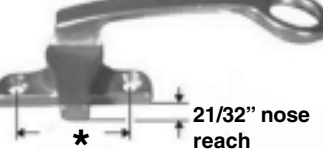
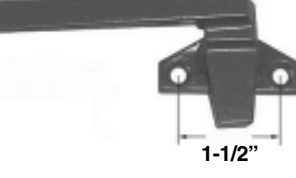

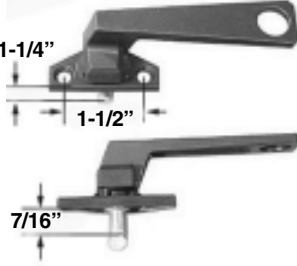
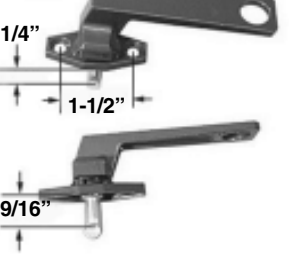

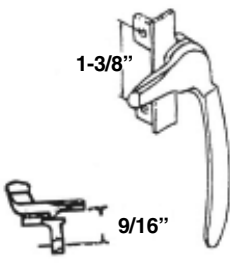
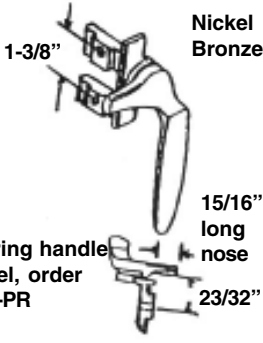

BLAINE SERVICE & SUPPLY

PROJECT OUT CAM HANDLES

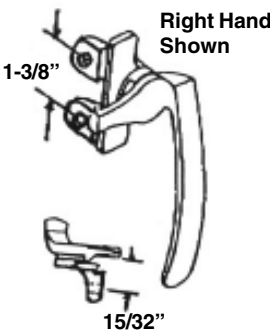
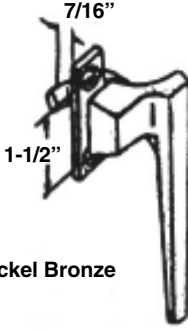
<p>08317 Lupton</p> <p>Nickel Bronze</p>  <p>Right Hand Shown</p>	<p>04954 Hopes</p> <p>Red Bronze</p>  <p>For upper fastener, order 4954-upper. Specify left or right</p> <p>Right Hand Shown</p>	<p>08485 Nickel Bronze Dark Statuary Bronze Red Bronze</p>  <p>Four hole mount Right Hand Shown</p> <p>Other variations available</p>
<p>09467 Lupton</p>  <p>Right Hand Shown</p>	<p>10076 Nickel Bronze</p>  <p>Right Hand Shown</p>	<p>10741 Red Bronze</p>  <p>Left hand only as shown</p>
<p>12600 Mason</p> <p>available in red bronze, nickel bronze or dark statuary bronze powder coat</p>  <p>Right Hand Shown</p> <p>* 1-3/8", 1-7/16", 1-1/2"</p>	<p>12601 Mason</p> <p>available in red bronze, nickel bronze or dark statuary bronze powder coat</p>  <p>Right Hand Shown</p> <p>* 1-3/8", 1-7/16", 1-1/2"</p>	<p>25.29.XX.102 as shown 25.29.XX.103 opposite</p> <p>Truth</p>  <p>Left hand shown</p>
<p>25.31.XX.103 as shown 25.31.XX.102 opposite</p>  <p>9/16" Nose Reach From Base Edge To End Of Nose</p>	<p>27.25.XX.103 as shown 27.25.XX.102 opposite</p> 	<p>27.32.XX.103 as shown 27.32.XX.102 opposite</p> 

BLAINE SERVICE & SUPPLY

I.G.W. / THRU-RAIL CAM HANDLES

<p>08487</p>  <p>Right hand shown</p>	<p>08774 Right hand shown</p>  <p>Nickel Bronze</p> <p>For ring handle model, order 8774-PR</p>	<p>12610 Mason</p> <p>Left Hand Shown</p>  <p>1-7/16"</p> <p>Also available in 1-3/8 and 1-1/2 inch hole centers</p>
<p>20176 Nickel Bronze</p>  <p>Right Hand Shown</p>	<p style="text-align: center;">THRU-RAIL CAM HANDLES</p>	<p>00190 Right hand shown</p>  <p>Nickel Bronze</p>
<p>00242-L Lupton</p> <p>Available in nickel bronze, red bronze or dark statuary bronze</p>  <p>Left hand shown</p> 		<p>00243-R Right Hand Shown</p>  <p>7/16" Lug Gap</p> <p>Specify Left or Right Hand</p> <p>Available in red bronze, nickel bronze or dark statuary bronze powder coated</p>
<p>00426-R</p>  <p>Right hand shown Specify Left or Right Hand</p>	<p>00428-R</p>  <p>7/16" Lug Gap</p> <p>For 1-1/8" Lug Gap, order 428- L-Spec or 428- R-Spec</p> <p>Right hand shown. Specify Left or Right Hand</p>	<p>00495 Bayley</p>  <p>Right Hand Configuration only</p>







BLAINE SERVICE & SUPPLY

I.G.W. CAM HANDLES

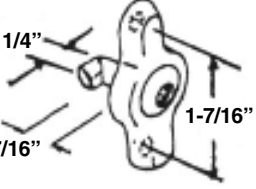
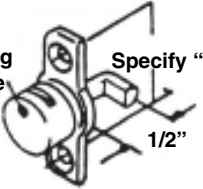
<p>25.39.XX.103 as shown 25.39.XX.102 opposite</p>	<p>25.41.XX.103 As shown 25.41.XX.102 Opposite</p> <p>Die Cast</p> <p>Available in nickel or chestnut bronze finish.</p>	<p>25.76.XX.102 as shown 25.76.XX.103 opposite</p> <p>Left Hand Shown</p> <p>Available in Black, Chestnut Bronze and Brushed Copper Nickel</p>
<p>00415 Right hand shown</p> <p>Unavailable Order #191w/ #192 See Page 27</p>	<p>04854 Nickel Bronze</p> <p>Available in right hand only, as shown.</p>	<p>04916 Cupples</p>
<p>04972 Kawneer</p> <p>10-24 Tapped Holes</p> <p>Right Hand Shown</p>	<p>05248 IGW Handle</p> <p>Nickel Bronze Right Hand Shown</p> <p>Kawneer</p>	<p>05335 Available In Nickel Bronze Or Red Bronze</p> <p>IGW Handle Right Hand Shown</p>
<p>05396 Right Hand Only As Shown</p> <p>Nickel Bronze</p>	<p>08302 Nickel Bronze</p> <p>Right Hand Shown</p> <p>Also available w/ special long nose. Order 8302-Spec-Long. Specify Left or Right Hand</p>	<p>08365 Nickel Bronze</p> <p>Right Hand Shown</p> <p>For keeper, order 8424</p>

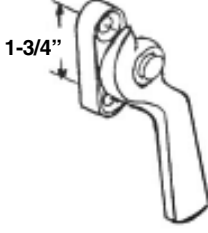
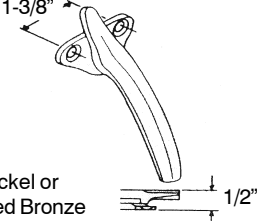

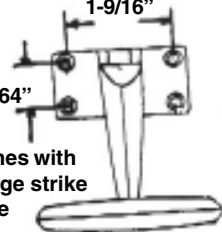

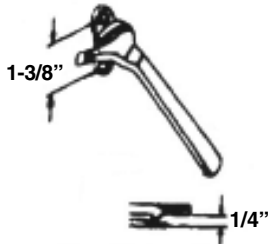
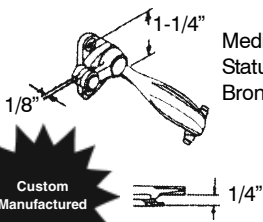
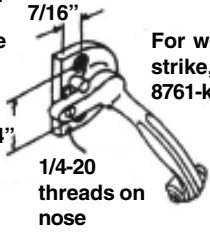
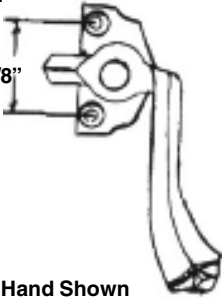
BLAINE SERVICE & SUPPLY

A.C. LOCKS / CAM HANDLES

<p>09263 Medium Statuary Bronze</p>  <p>Order 2053-1/4 Wrench</p>	<p>12551 Left Hand Shown</p> <p>10-24 Locking Handle</p>  <p>Specify "A"</p> <p>1/2"</p> <p>Available in nickel bronze or red bronze</p>	<p>12625 Order 12560 3/32 Wrench</p>  <p>Available in nickel bronze or red bronze</p> <p>Avail: 1-3/8", 1-7/16" & 1-1/2" hole spacing</p>
<p>20313</p>  <p>Used with 28 series key operated Custodial Lock</p> <p>7/16"</p>	<p>PROJECT IN CAM HANDLES</p>	<p>00184</p>  <p>1-3/4"</p> <p>Red Bronze</p>
<p>00402 Hopper Handle</p>  <p>Nickel or Red Bronze</p> <p>1-3/8"</p> <p>1/2"</p>	<p>04040</p>  <p>1-5/8"</p> <p>Right Hand swings to right Left Hand swings to left</p> <p>Red Bronze</p>	<p>04149 Red Bronze</p>  <p>1-9/16"</p> <p>43/64"</p> <p>Comes with wedge strike plate</p>
<p>SIMPLEX CAM HANDLES</p>	<p>00497 Specify left or right hand</p> <p>7/32" from back of base to underside of nose</p>  <p>Truscon Republic Steel</p> <p>19/32" nose reach</p> <p>1-3/8"</p> <p>Available in red bronze or nickel bronze</p> <p>Right Hand Shown</p>	<p>08036 Red Bronze</p>  <p>1-3/8"</p> <p>1/4"</p> <p>Right Hand Shown</p>
<p>08116 Simplex Handle</p> <p>Right Hand Shown</p>  <p>1-1/4" Medium Statuary Bronze</p> <p>1/8"</p> <p>1/4"</p> <p>Custom Manufactured</p>	<p>08761 Red Bronze</p> <p>3-hole</p>  <p>7/16"</p> <p>1-1/4"</p> <p>1/4-20 threads on nose</p> <p>Right hand shown</p> <p>9/32"</p> <p>For wedge strike, order 8761-k</p>	<p>09441</p>  <p>1-3/8"</p> <p>Right Hand Shown</p>



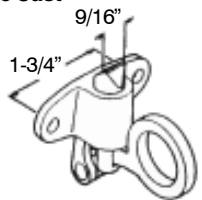
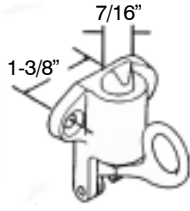
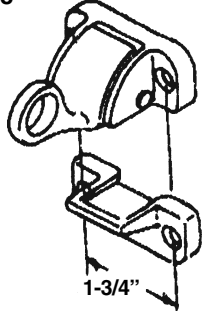
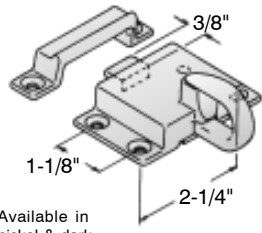
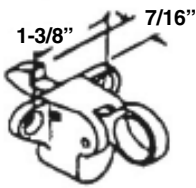
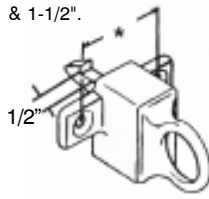

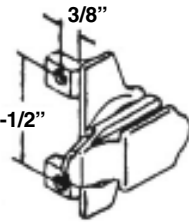
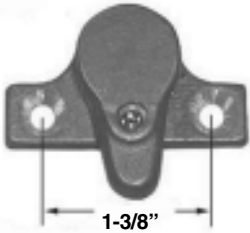
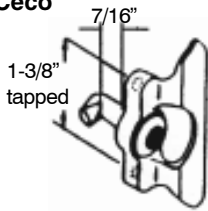
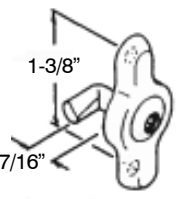
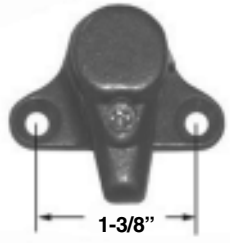
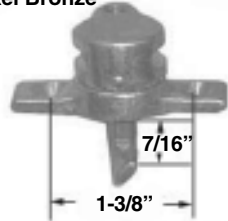





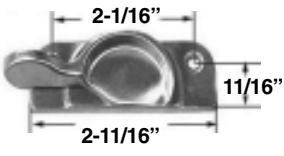
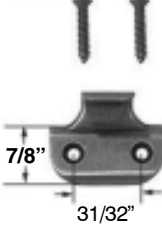
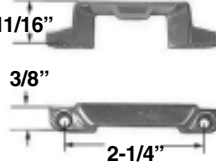

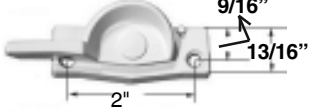
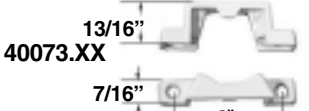
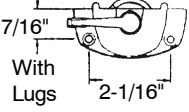
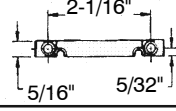

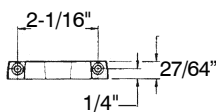
BLAINE SERVICE & SUPPLY

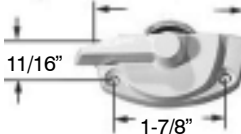
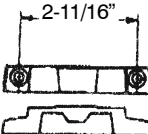
SPRING CATCHES / A.C. LOCKS

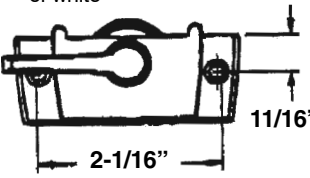
<p>00144 Truscon</p> <p>Red Bronze</p> <p>This model also available for project out application. Order No. 00144-Rev</p> 	<p>00147 Available in Nickel Bronze and Red Bronze</p>  <p>For Surface Type Keeper, order 00147-SK</p>	<p>00484 Fenestra</p> <p>Die Cast</p>  <p>Available in Aluminum or bronze painted finish</p>
<p>02404</p>  <p>Nickel Bronze</p>	<p>04328</p> 	<p>04332</p>  <p>Available in nickel & dark bronze</p>
<p>05131 Ceco</p>  <p>Available in nickel bronze or dark statuary bronze</p>	<p>12401 Mason</p> <p>*Available in 1-3/8", 1-7/16" & 1-1/2".</p>  <p>Available in nickel or red bronze</p>	<p>00039-5/32"</p> <p>5/32" Hex</p>  <p>Also available with 1/8" hex. Order #00039-1/8"</p>
<p>01206 Nickel Bronze</p> 	<p>01209 Available in red brass and nickel bronze</p> 	<p>08021 Order #02053-1/4" Hex Wrench</p> <p>Ceco</p>  <p>Available in nickel or red bronze</p>
<p>08043 Available in Nickel or Red Bronze</p> <p>Ceco</p>  <p>Order #2053-1/4 Hex Wrench</p>	<p>08098 Ceco</p> 	<p>08454 1/2" lug gap - 08454-1/2 11/16" lug gap - 08454-11/16</p> <p>Nickel Bronze</p>  <p>For wrench handle, order 0039-5/32</p>

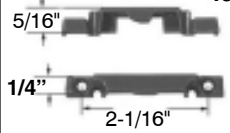

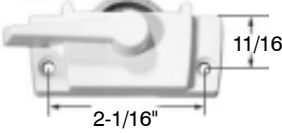
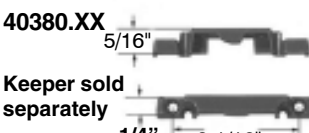

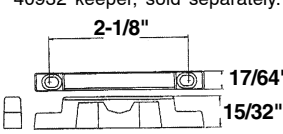
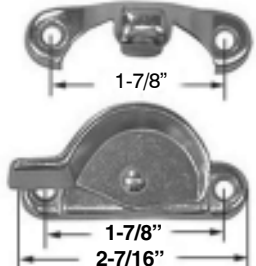
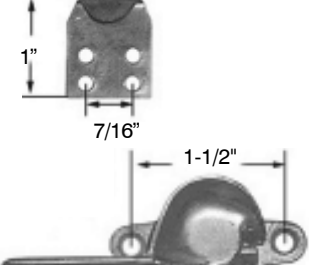

BLAINE SERVICE & SUPPLY

SWEEP LATCHES

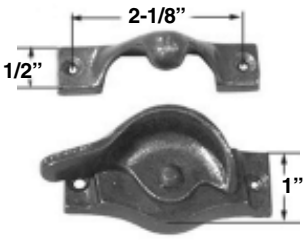
<p>17.02.XX.001</p>  <p>Restoration Lock</p>  <p>2-1/16" hole centers 11/16" set back</p>	<p>18.16.XX.102 Finger Lift</p>  <p>7/8" 31/32"</p> <p>12398.XX</p>  <p>11/16" 3/8" 2-1/4"</p> <p>Screws not included. We recommend #6 flat head phillips and determine your desired length. We can provide.</p> <p>XX = Bright Brass - 13 Antique Brass - 14 Nickel - 19</p>	<p>17.14.XX</p>   <p>9/16" 13/16" 2"</p> <p>Bronze painted or white</p> <p>Keeper sold separately.</p> <p>40073.XX</p>  <p>13/16" 7/16" 2"</p>
<p>17.19.XX.200</p>  <p>7/16" 2-1/16"</p> <p>With Lugs</p> <p>Beige, Bronze painted or white</p> <p>40320.XX</p>  <p>2-1/16" 5/16" 5/32"</p> <p>Keeper sold separately.</p>	<p>17.23.XX.200</p>  <p>Without Lugs</p>  <p>2-1/16" 7/16"</p> <p>Bronze painted, gold painted, chestnut bronze or white</p> <p>40367.XX</p>  <p>2-1/16" 27/64" 1/4"</p> <p>Keeper sold separately</p>	<p>17.31.XX.100</p>  <p>Entrygard Available in bronze painted or white</p>  <p>11/16" 1-7/8"</p> <p>40367.XX</p>  <p>2-11/16"</p> <p>Keeper sold separately</p>
<p>17.33.XX.200</p>  <p>Available in beige, black, bronze painted, chestnut bronze, clay or white</p>  <p>11/16" 2-1/16"</p> <p>Keeper no. 40891 sold separately</p>	<p>17.34.XX.200</p>  <p>Trimline</p>  <p>7/16" 2-1/16"</p> <p>Available in beige or white.</p> <p>40380.XX</p>  <p>5/16" 1/4" 2-1/16"</p> <p>Keeper sold separately</p>	<p>17.35.XX.300</p>  <p>With Lugs</p>  <p>11/16" 2-1/16"</p> <p>Bronze painted or white</p> <p>40380.XX</p>  <p>5/16" 1/4" 2-1/16"</p> <p>Keeper sold separately</p>
<p>17.38.XX.200</p>  <p>Available in gold painted, beige or white</p>  <p>7/16" 2-1/16"</p> <p>40932 keeper, sold separately.</p>  <p>2-1/8" 17/64" 15/32"</p> <p>Several colors available</p>	<p>00501</p> <p>Brass Finished Cast Zinc</p>  <p>1-7/8" 1-7/8" 2-7/16"</p>	<p>01550-Set</p>  <p>1" 7/16" 1-1/2"</p>

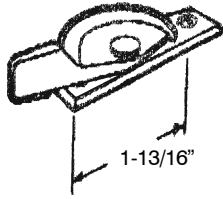

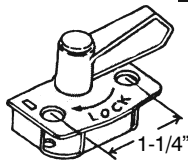
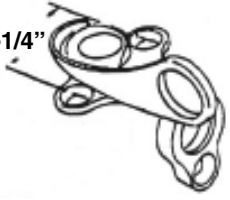

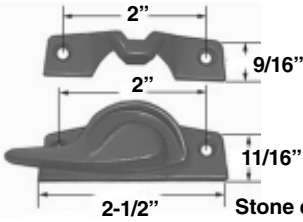
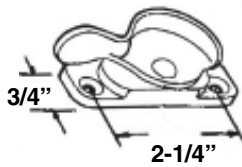
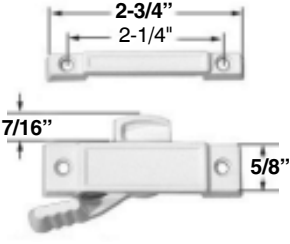
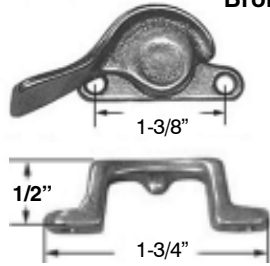
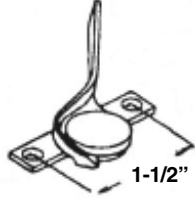
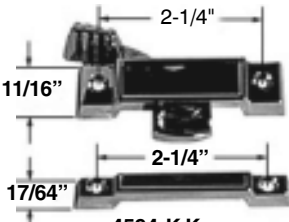
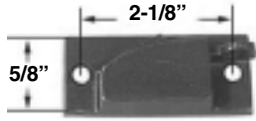
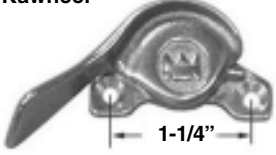
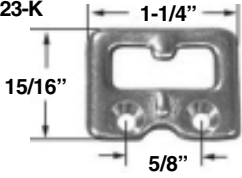
BLAINE SERVICE & SUPPLY

SWEEP LATCHES

<p>04028</p> 	<p>04210</p>  <p>Black Finish</p>  <p>Cast Zinc</p>	<p>04216</p>  <p>Champagne</p>  <p>Comes with 04216-k keeper</p>
<p>04249</p> <p>Nickel Bronze</p>  <p>Order 04249-K keeper</p>	<p>04254</p> <p>Lock & Keeper Nylon</p>   <p>2 inch hole centers</p> <p>Stone color finish or white</p>	<p>04520</p> <p>3/4" total height</p>  <p>Dark statuary bronze. For 2-5/16" hole centers. Order 04520-2-5/16. Available in red bronze, nickel bronze and aluminum.</p>
<p>04550</p> 	<p>04583</p> <p>Nickel Bronze</p>  <p>04583-K Keeper Sold Separately</p>	<p>04591</p> <p>Handed - Left Hand Shown</p>  <p>Nickel Bronze</p>
<p>04594</p> <p>Black, white, natural zinc or brown</p>  <p>4594-K Keeper See keyed sold separately version Order 4594-w/key Black or white only</p>	<p>04603</p>  <p>Order 4603-K Keeper separately</p>	<p>04623</p> <p>Kawneer</p>  <p>4623-K</p> 

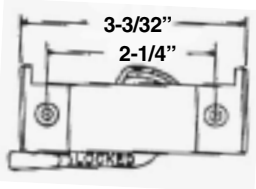
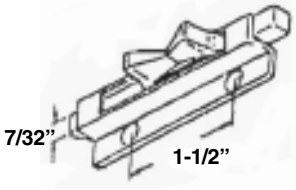
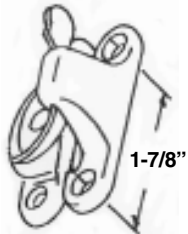
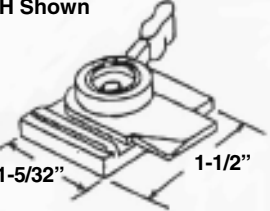

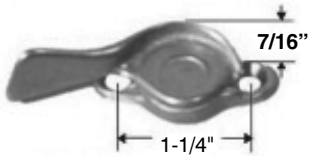

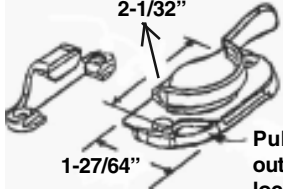
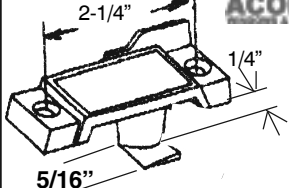
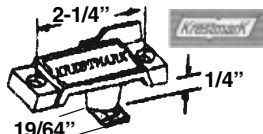
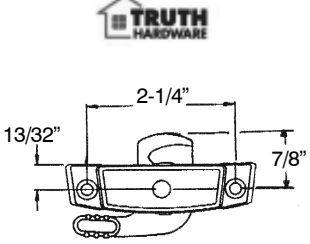
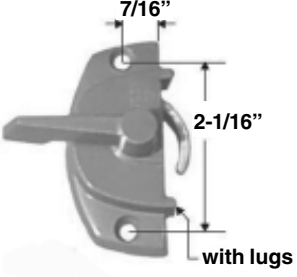
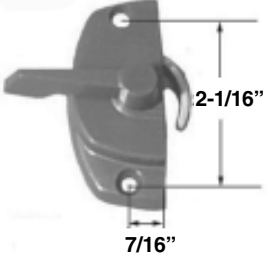

BLAINE SERVICE & SUPPLY

SWEEP LATCHES

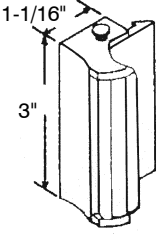
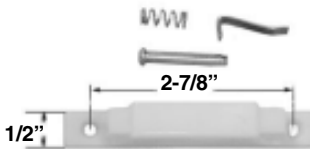
<p>04392 Available in black or white diecast</p>  <p>For keeper order 04392-K</p>	<p>04627</p> 	<p>04644 Overall height- 45/64"</p>  <p>Brass plated die cast</p> <p>For dull nickel finish order 04644-016</p>
<p>04652 Thermalgard</p> <p>Specify left or right R H Shown</p>  <p>White</p> <p>Comes with center screw</p>	<p>04675-R NuPrime/ Seasonall Zinc Plated Die Cast</p>  <p>Keeper sold separately</p> <p>04675-K</p> 	<p>04703 Nickel Bronze</p>  <p>Order 04703-k keeper separately</p> <p>Right hand shown Specify left or right hand</p>
<p>04709</p>  <p>Right Hand Shown. Specify Left or Right Hand</p> <p>Order 04513-K Keeper</p>	<p>20667-Assy-003 Marvin</p> <p>20667-Assy-067</p>  <p>Pull out lock lever</p> <p>Solid polished brass or white finish</p>	<p>A07538148WC White</p>  <p>ACORN</p>  <p>Kreston</p> <p>A07538230BK Black</p>
<p>A8164-00-02 Black</p> <p>A8164-00-WH White</p>  <p>TRUTH HARDWARE</p>	<p>17.19</p>  <p>with lugs</p>	<p>17.23</p> 

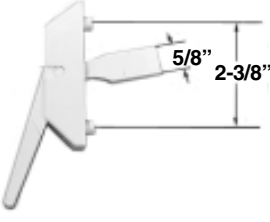
BLAINE SERVICE & SUPPLY

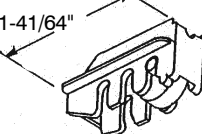
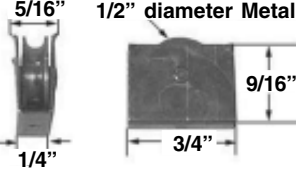
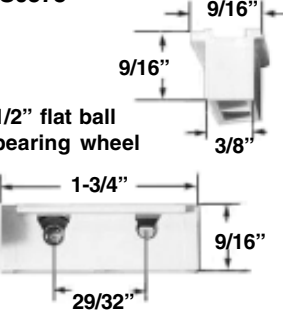
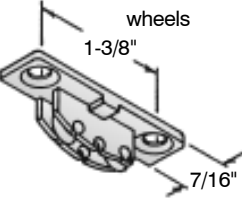
HORIZONTAL SLIDING LATCHES / ROLLERS & GUIDES

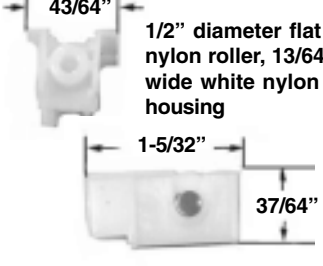
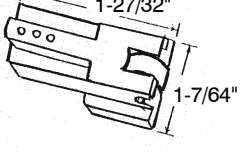
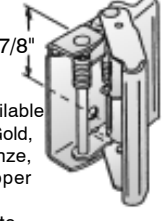
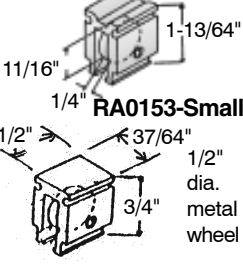
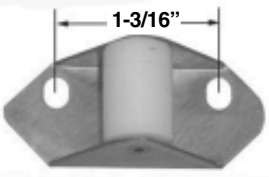
<p>HS0001</p> <p>Premiere</p>  <p>Nylon with aluminum latch. Black finish.</p> <p>2-1/8" hole centers</p>	<p>HS0016</p> 	<p>HS0050</p> 
<p>HS0496</p> 	<p>HS0710</p> 	<p>HS0521</p> <p>Acorn</p>  <p>5/8" dia. metal flat wheel</p>
<p>HS0561</p>  <p>5/16" 1/2" diameter Metal</p> <p>1/4" 3/4" 9/16"</p>	<p>HS0573</p>  <p>9/16" 9/16" 1/2" flat ball bearing wheel 3/8" 1-3/4" 9/16" 29/32"</p>	<p>HS0577</p>  <p>5/16" dia. flat dual metal wheels</p> <p>1-3/8" 7/16"</p> <p>5/16" dia. roller</p>
<p>HS0585</p>  <p>7/8" diameter wheel. Specify Nylon or Steel</p>	<p>HS0588 Reynolds</p>  <p>43/64" 1/2" diameter flat nylon roller, 13/64" wide white nylon housing</p> <p>1-5/32" 37/64"</p>	<p>HS0607</p>  <p>1-27/32" 1-7/64"</p> <p>1/2" dia. flat metal wheel</p>
<p>17.13</p> <p>Truth</p>  <p>7/8"</p> <p>Available In Gold, Bronze, Copper & White</p>	<p>RA0153</p>  <p>11/16" 1/4" RA0153-Small 1-13/64" 1/2" 37/64" 3/4" 1/2" dia. metal wheel</p>	<p>RA169</p>  <p>1-3/16"</p>

BLAINE SERVICE & SUPPLY

CHANNEL BALANCES

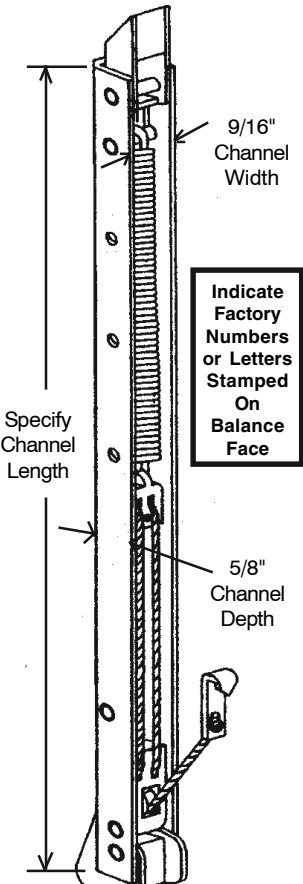
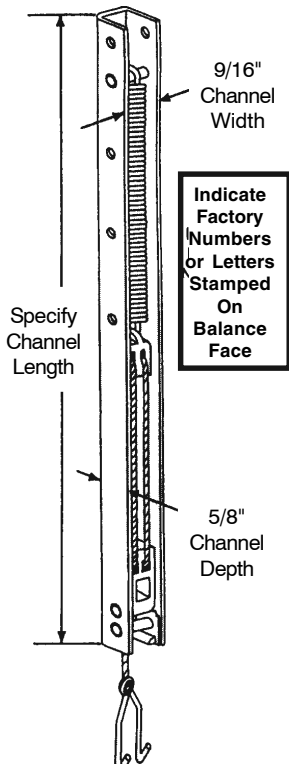
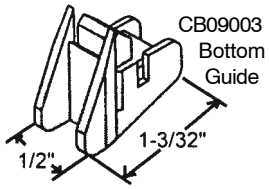
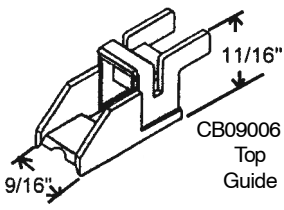
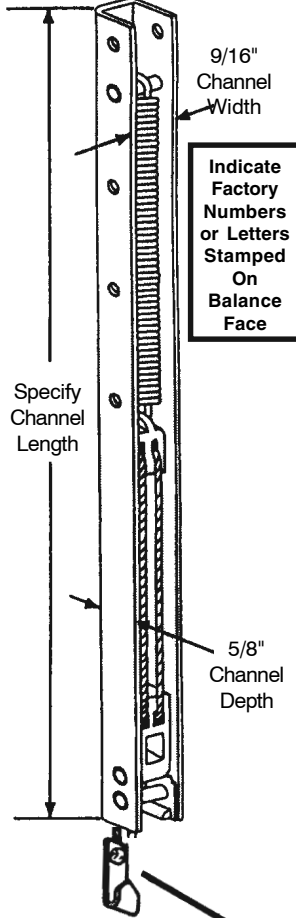
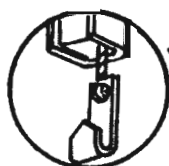
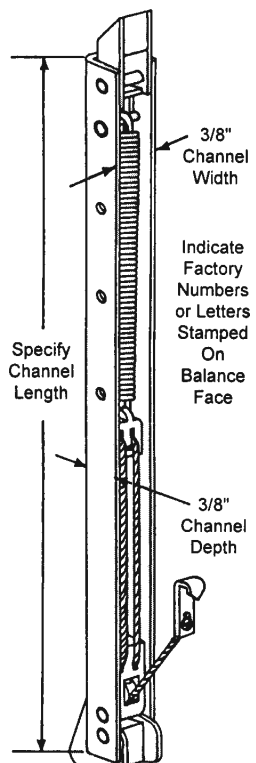
<p>CB 0 SERIES Channel Balance 9/16" channel width*</p>  <p>9/16" Channel Width</p> <p>Specify Channel Length</p> <p>5/8" Channel Depth</p> <p>Indicate Factory Numbers or Letters Stamped On Balance Face</p>	<p>Information required for ordering:</p> <ol style="list-style-type: none"> 1. Measure channel length (do not include plastic end guides). 2. Check numbers stamped on channel. 3. Identify series. 	<p>CB 5 SERIES Channel Balance 9/16" channel width</p>  <p>9/16" Channel Width</p> <p>Specify Channel Length</p> <p>5/8" Channel Depth</p> <p>Indicate Factory Numbers or Letters Stamped On Balance Face</p>
<p>*For 3/8" channel width, order CB-4 Series</p> <p>Most Commonly Used Accessories For CB 0 Series Balances. Please specify when ordering.</p>  <p>CB09003 Bottom Guide</p> <p>1/2" 1-3/32"</p>  <p>CB09006 Top Guide</p> <p>9/16" 11/16"</p>	<p>CB 3 SERIES Channel Balance 9/16" channel width</p>  <p>9/16" Channel Width</p> <p>Specify Channel Length</p> <p>5/8" Channel Depth</p> <p>Indicate Factory Numbers or Letters Stamped On Balance Face</p>  <p>Same as the CB5 series but with a different gooseneck clip.</p>	<p>CB 4 SERIES CHANNEL BALANCE</p>  <p>3/8" Channel Width</p> <p>Specify Channel Length</p> <p>3/8" Channel Depth</p> <p>Indicate Factory Numbers or Letters Stamped On Balance Face</p>

BLAINE SERVICE & SUPPLY

CHANNEL BALANCES & ACCESSORIES

<p>CB 2 SERIES Channel Balance 9/16" channel width Non ribbed</p> <p>9/16" Channel Width</p> <p>5/8" Channel Depth</p> <p>Specify Channel Length</p> <p>Indicate Factory Numbers or Letters Stamped On Balance Face</p>	<p>CB9001-1 Capitol</p> <p>White</p> <p>Top Guide</p>	<p>CB9002 Capitol</p> <p>White</p> <p>Bottom</p>
	<p>CB9003 Bottom</p> <p>White</p>	<p>CB9004 Bottom</p> <p>White</p>
<p>CB 6 SERIES Channel Balance Used in jambliners (ribbed)</p> <p>Ribbed</p> <p>9/16" Channel Width</p>	<p>CB9005 Bottom</p> <p>White</p>	<p>CB9006 White</p> <p>Top Guide</p>
	<p>CB9007 Crossly</p> <p>White</p> <p>Top Guide</p>	<p>CB9012 Sash Cam</p> <p>Black or white</p>
<p>CB9013</p> <p>Take Out Clip</p>	<p>CB9018</p> <p>Black or white</p>	
<p>CB9020 Top</p> <p>White</p>	<p>CB9030 order CB9033</p> <p>White</p>	

BLAINE SERVICE & SUPPLY

CHANNEL BALANCE ACCESSORIES

<p>CB9032 White</p>	<p>CB9033 White</p>	<p>CB9065</p> <p>Black or white</p>
<p>CB9067 Black or white</p>	<p>CB9071 Top Guide White</p>	<p>CB9083 White</p>
<p>CB9087</p> <p>Black or white</p>	<p>CB9096</p> <p>Black or white</p>	<p>CB9119 white nylon</p> <p>Handed L/R Pair</p>
<p>CB9248</p> <p>white or black</p>	<p>CB9252-Spec White</p>	<p>CB9256 Louisiana Pacific</p> <p>White or Black</p>
<p>CB9266</p> <p>Black or white</p>	<p>CB9268-A Top Capitol Black or white</p>	<p>CB9268-B Bottom Capitol Black or white</p> <p>Original is clear plastic</p>
<p>CB9270-L/R Pair White</p> <p>For zinc cam, order CB9270-1 For nylon pawl (brake), order CB9270-2</p>	<p>CB9274 EFCO CAM Black</p>	<p>CB9276 Howard Metal</p>

BLAINE SERVICE & SUPPLY

TUBE BALANCES

WB7900 Series Tube Balance

Specify Tube Length & Bearing Color When Ordering

Actual Diameter 9/16". Referred to as 5/8" in Trade.

SASH WEIGHT

Orange/Red- Sash load to 25 Lbs
 Blue- Sash load to 35 Lbs
 Black- Sash load for 36 - 40 lbs

Specify Tube Length

Aluminum Tube

Order **WB0618** Tension Tool

WB0014
 Most commonly used accessory with WB7900 Series Balance

Bearing
 Cross Pin
 Rod

For
 Double / Single Hung, Non-Tilt /
 Non-Take Out Style Windows

WB79-AT Series Tube Balance

Specify Tube Length & Bearing Color When Ordering

Actual Diameter 9/16". Referred to as 5/8" in Trade.

Specify Tube Length

Aluminum Tube

Bearing
 Rod

WL0001
 Tilt Latch

WB01047

WB7700 Series Tube Balance

Specify Tube Length & Bearing Color When Ordering

3/8" Diameter

SPECIFY BEARING COLOR

White - Standard
 Orange/Red- Medium
 Green - Heavy

Specify Tube Length

Aluminum Tube

Order **WB618** Tension Tool

WB0010
 Most commonly used accessory with WB7700 Series Balance

Bearing
 Rod
 Cross Pin

WB77-IT Series Tube Balance

Specify Tube Length & Bearing Color When Ordering

3/8" Diameter

Specify Tube Length

Aluminum Tube

Order **WB0618-AT** Double Prong Tension Tool

WB01042
 Most commonly used accessory with WB77-IT Series Balance

Bearing
 Rod

For Tilt Windows

BLAINE SERVICE & SUPPLY

TUBE BALANCES & ACCESSORIES

<p>WB79-TO Series Tube Balance Specify Tube Length & Bearing Color When Ordering</p> <p>Actual Diameter 9/16". Referred to as 5/8" in Trade.</p> <p>Three Rod Extensions</p> <p>S - 1-5/8" R - 2-5/8" RR - 3-5/8"</p> <p>SASH WEIGHT Orange / Red - Medium Blue - Heavy</p> <p>Specify Tube Length</p> <p>Aluminum Tube</p> <p>Bearing</p> <p>Rod Extension</p> <p>Rod</p> <p>5/8"</p> <p>Specify Rod Extension when ordering</p> <p>Order WB0618 Tension Tool</p> <p>WB0213 Please specify if required at time of order</p>	<p>WB0002-L/R white</p> <p>23/64"</p> <p>1"</p> <p>1-3/8"</p> <p>Cupples</p>	<p>WB0004 white</p> <p>1/8"</p> <p>1-3/8"</p> <p>1/4"</p> <p>3/8"</p> <p>7/8"</p> <p>For version with wire loop, order WB0004-Spec</p>
<p>WB77-TO Series Tube Balance Specify Tube Length & Bearing Color When Ordering</p> <p>3/8" Diameter</p> <p>SPECIFY BEARING COLOR</p> <p>White - Standard Orange/Red - Medium Green - Heavy</p> <p>Aluminum Tube</p> <p>Bearing</p> <p>Rod</p> <p>1/2"</p> <p>Order WB0618 Tension Tool</p> <p>WB0202 Most commonly used accessory with WB7700-TO Series Balance</p> <p>Please specify if required at time of order</p>	<p>WB0010 Metal</p> <p>1-11/16"</p> <p>5/16"</p>	<p>WB0014 Metal</p> <p>1-1/4"</p> <p>1/2"</p>
<p>WB0018 Metal</p> <p>2-7/8"</p> <p>3/8"</p>	<p>WB0411 Metal</p> <p>3/8"</p> <p>2-13/16"</p> <p>1-1/2"</p> <p>w/ rivet</p> <p>replacement may differ slightly from original</p>	
<p>WB0436 white</p> <p>UNIQUE</p> <p>1-1/2"</p> <p>7/16"</p>	<p>WB0500 L/R Pair</p> <p>Metal</p> <p>1-7/64"</p> <p>1-9/16"</p> <p>3/4"</p> <p>3/8"</p>	
<p>WB0616 Black or white</p> <p>1/2"</p> <p>5/8"</p> <p>11/16"</p>	<p>WB0618</p> <p>WB-618-AT</p>	
<p>WB0627</p> <p>7/16"</p> <p>5/8"</p> <p>3/4"</p> <p>Black or white</p>	<p>WB0650</p> <p>1/4"</p> <p>3/8"</p> <p>2-3/4"</p> <p>Die Cast</p>	

BLAINE SERVICE & SUPPLY

TUBE BALANCES / JAMB STRETCHER

WB8100 ULTRA-LIFT BALANCE (Special Order)

Makes 80-Lb Sash Easy To Lift !

30-80 lbs per pair capacity Available 20-1/2" - 60-1/2"

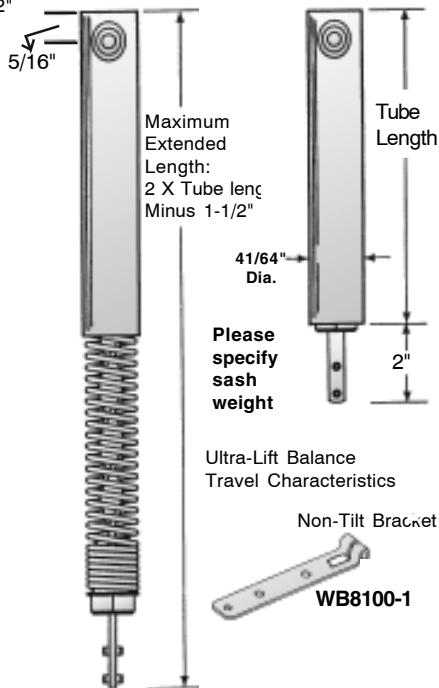

- Lifts 70% of sash weight vs AAMA's 40% minimum.
- Useable with both tilt and non-tilt windows.
- Fits most C-20 and HC-40 AAMA-Grade single and double hung windows.
- Fits most large architectural wood windows.

Call Customer Service for more details

WB7000 SERIES

5/8" PLASTIC TUBE BALANCE

Tube diameter 9/16" but considered 5/8" in the trade

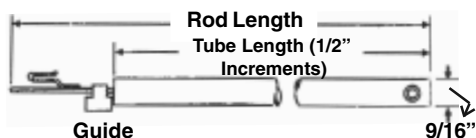

Black Tube
Standard
Gray Available

WB6000 SERIES

3/8" TUBE BALANCE

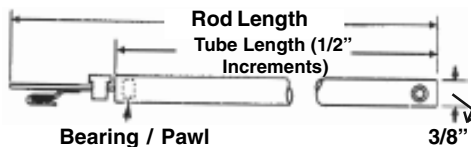

Call for information on available lengths, special lengths and accessories.

JAMB STRETCHER

The **JAMB STRETCHER** enables you to spread a vinyl jamb pocket in order to replace balances, shoes or other components without the need to cut into the jamb or melting the vinyl with a hot air gun.

Replace components in a fraction of the time compared to other methods. This is an excellent tool for factory use or field repair!
Designed for use in vinyl jambs only!

3 Easy Steps

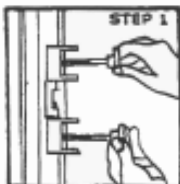

1. Position one spreader below and one spreader above the item needing removal.

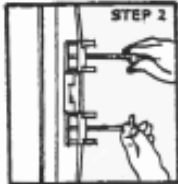

2. Turn knobs clockwise by hand or with a hex bit drill gun to spread jamb.

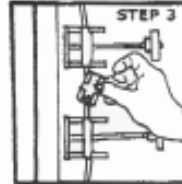

3. Remove / replace components

Part No. WB1449

ULTRA-LIFT[®] nt



**A HYBRID BALANCE SYSTEM FOR
HEAVY SASH 50 - 100 LBS**

HIGH LIFT ASSISTANCE
MAKES HEAVY SASH EASY TO OPERATE

.670 TUBE DIAMETER
FITS MOST COMMON BALANCE POCKETS

BOOSTED FORCE CURVE
HELPS INITIATE OPENING OF SASH

CLASS 5 RATING
BALANCE LIFTS 70% OF SASH WEIGHT

LOW CARBON COATED STEEL ROD
RUST RESISTANT WITH LOW FRICTION PROPERTIES

WHITE OR GRAY PVC TUBE COVER
PROVIDES CONTAMINANT PROTECTION
TUBE BLENDS INTO WINDOW COLOR

STANDARD ROD END CONFIGURATION
COMPATIBLE WITH A WIDE RANGE OF WINDOW DESIGNS

CUSTOM BUILT AND IDENTIFIED
MAXIMUM PERFORMANCE WITH EASY INSTALLATION



ULTRA-LIFT[®] nt WEIGHT CAPACITY CHART

BALANCE SIZES AVAILABLE		
ULTRA-LIFT [®] nt BALANCE NO.	TUBE LENGTH	WEIGHT RANGE (PER PAIR)
30	30.5	80 - 100 LBS
31	31.5	80 - 100 LBS
32	32.5	80 - 100 LBS
33	33.5	80 - 100 LBS
34	34.5	80 - 100 LBS
35	35.5	80 - 100 LBS
36	36.5	80 - 100 LBS
37	37.5	80 - 100 LBS
38	38.5	80 - 100 LBS
39	39.5	80 - 100 LBS
40	40.5	80 - 100 LBS
41	41.5	80 - 100 LBS
42	42.5	80 - 100 LBS
43	43.5	80 - 100 LBS
44	44.5	80 - 100 LBS
45	45.5	80 - 100 LBS
46 - 60	46.5 - 60.5	80 - 100 LBS

HOW TO ORDER:

Please use the chart above to help you in choosing the correct part to order.

1. Determine your sash weight and tube length needed.
2. Locate proper balance number utilizing the ULTRA LIFT[®] weight capacity chart

MEGA-LIFT™



**A HYBRID BALANCE SYSTEM FOR
HEAVY SASH FROM 100 - 130 LBS**



**COMBINE BEST QUALITIES OF TORSION AND ESTENSION
SPRINGS**
PROVIDES EXCEPTIONAL OPERATING CHARACTERISTICS

TUBE DIAMETER OF .575
FITS MOST SIDELOAD HC/AW DESIGNS

BOOSTED FORCE CURVE
HELPS INITIATE OPENING OF SASH

CUSTOM BUILT FOR SPECIFIC APPLICATION
DELIVERS OPTIMAL OPERATING FORCE

HIGH LIFT ASSISTANCE
ALLOWS THE HEAVIEST SASH TO OPERATE EASILY

CLASS 5 RATING
BALANCE LIFTS 70% OF SASH WEIGHT

WHITE OR GRAY PVC TUBE COVER
PROVIDES CONTAMINANT PROTECTION
TUBE BLENDS INTO WINDOW COLOR

**WEIGHT RANGES: 100 - 130 LBS
LENGTHS: 30 - 60 INCHES
AAMA 902-07 CLASS 5
VERIFIED COMPONENT**

MEGA-LIFT WEIGHT CAPACITY CHART

BALANCE SIZES AVAILABLE		
MEGA-LIFT BALANCE NO.	TUBE LENGTH	WEIGHT RANGE (PER PAIR)
30	29.5	100 - 130 LBS
31	30.5	100 - 130 LBS
32	31.5	100 - 130 LBS
33	32.5	100 - 130 LBS
34	33.5	100 - 130 LBS
35	34.5	100 - 130 LBS
36	35.5	100 - 130 LBS
37	36.5	100 - 130 LBS
38	37.5	100 - 130 LBS
39	38.5	100 - 130 LBS
40	39.5	100 - 130 LBS
41	40.5	100 - 130 LBS
42	41.5	100 - 130 LBS
43	42.5	100 - 130 LBS
44	43.5	100 - 130 LBS
45	44.5	100 - 130 LBS
46 - 60	45.5 - 59.5	100 - 130 LBS

HOW TO ORDER:

Please use the chart above to help you in choosing the correct part to order:

1. Determine your sash weight and tube length needed.
2. Locate proper balance number utilizing the ULTRA LIFT® weight capacity chart

**** Consult with Caldwell Engineering to verify accessory capability.****

BLAINE SERVICE & SUPPLY

TUBE BALANCE ACCESSORIES

<p>WB0651</p> <p>1-5/8" 2-1/32" 39/64" Black Cam</p>	<p>WB0652</p> <p>1-17/64" 2-1/16" 35/64" Tan Cam</p>	<p>WB0653</p> <p>1-17/64" 2" Red Cam</p>
<p>WB0657 Plunger</p> <p>White Nylon</p> <p>2-3/4" 11/16"</p>	<p>WB0658-L/R Anti draft block</p> <p>1-3/16" 5/8" 15/16" Black or white</p>	<p>WB1042 Used with WB77-IT Series</p> <p>15/16" 1-25/32" 11/32" White Cam</p>
<p>WB1047</p> <p>Used with WB79-AT Series</p> <p>1-9/32" 2" 17/32" Blue Cam</p>	<p>WB1062 Metal</p>	<p>WB1064 For Crestline</p> <p>Assy. includes (1) of each piece shown</p> <p>30" spring, order WB7500-Spring-30 & cut to size</p> <p>Metal</p>
<p>WB1067</p> <p>Replaces Thermal-Gard white</p> <p>5/8" 2-1/32" 1-1/4"</p>	<p>WB1073 3 pc. foot assembly</p> <p>15/16" 9/16" 1/2"</p> <p>Cast zinc replacement</p>	<p>WB1083-L/R-Upper Black only</p> <p>1" 1-1/8" 1-11/16" 5/8"</p> <p>WB-1083-L/R-Lower</p> <p>1-13/16"</p>
<p>WB1111</p> <p>9/16" 1-3/16" 2"</p> <p>with cast zinc cam</p>	<p>WB1122 L/R Pair</p> <p>1-5/8" 1" 1-1/16" 5/16"</p> <p>Cast Zinc</p>	<p>WB1299 Metal L/R Pair</p> <p>3/8" 5/16" 3/4" 2-1/8"</p>
<p>WB1317 Cast Zinc</p> <p>5/32" 3-3/16" 1" 1/4"</p>	<p>WB1315 Cast Zinc</p> <p>1-3/8" 1-3/8" 1/4"</p>	<p>WB8100-1 Metal</p> <p>1-3/8" 5/8" 3-13/16" 9/16"</p> <p>Non tilt bracket for WB8100 Ultra lift</p>

BLAINE SERVICE & SUPPLY

JAMBLINERS



**WB7500 SERIES
REPLACEMENT ALUMINUM WINDOW CHANNELS**

**For Wood Double Hung Window
With 1-3/8" Sash**

Replace old style tubular balances or rope and pulley. Designed for 1-3/8" sash. One piece jamb strip reduces air infiltration. Baked-on white enamel finish, metal "T" hangers and flocked springs. Use (1) pair to repair (1) double hung window. See chart at right.

TO ORDER:

Measure overall window height of window opening and / or glass height of sash only. Select from chart at right.

Absolute maximum sash weight: 26 lbs.

Replacement Metal "T" Hanger, included with jambliner



WB7517

Part Number	Window Height	Glass Height
WB-7501	2'2"	10"
WB-7502	2'6"	12"
WB-7503	2'10"	14"
WB-7504	3'2"	16"
WB-7505	3'6"	18"
WB-7506	3'10"	20"
WB-7507	4'2"	22"
WB-7508	4'6"	24"
WB-7509	4'10"	26"
WB-7510	5'2"	28"
WB-7511	5'6"	30"
WB-7512	5'10"	32"
WB-7513	6'2"	34"
WB-7514	6'6"	36"
WB-7515	6'10"	38"
WB-7516	7'2"	40"

Caution: Our jambliners are cut 14 degrees on sill end.

WB7300 Series Tilt Liner was developed to provide a durable, trouble-free removable weatherstrip balance for single glazed windows.

The Liner
Rigid PVC with flex-leaf open construction. The sash is held in place solidly yet the individual leaves will move out of the way to allow for tilting. Springs are concealed and protected. Spring noise is eliminated with a sound deadener attached to each spring.

Backing Foam
Advanced foam with a closed cell edge is standard. The foam acts as a compression spring with the closed cell edge providing a superior air and water seal.

Note: Our jambliners are cut at approximately a 14 degree angle.

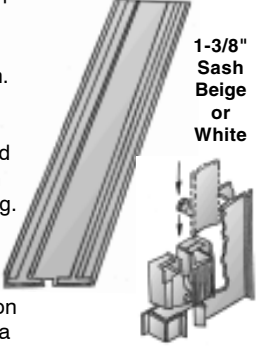

1-3/8" Sash Beige or White

Part Number	Glass Height	Opening Height
WB-7300	12"	2'6"
WB-7301	14"	2'10"
WB-7302	16"	3'2"
WB-7303	18"	3'6"
WB-7304	20"	3'10"
WB-7305	22"	4'2"
WB-7306	24"	4'6"
WB-7307	26"	4'10"
WB-7308	28"	5'2"
WB-7309	30"	5'6"
WB-7310	32"	5'10"
WB-7311	34"	6'2"
WB-7312	36"	6'6"

The Carrier System
Simple and durable. Large one piece carriers provide easy sash installation and insure proper balancing with self-adjusting friction. Large mushroom sash pins capture the carriers to eliminate carrier fly-up.

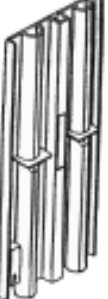

**WB7200 SERIES*
Non-Tilt**

**FOR INSULATED GLASS WITH 1-3/8" OR 1-1/4" SASH
Beige**

Repair and upgrade old windows with an energy efficient vinyl or metal jambliner. These jambliners replace old tubular style balances or rope and pulley systems.

Other Sizes Available

Standard 14 degree miter cut

- Rigid Vinyl Weatherstrip
- Continuous Tube Cover
- Friction Platform
- Speed Lok Stops
- Sound Deadener
- Dust And Air Plug

1-3/8" Sash	1-1/4" Sash	Glass Height	Opening Height
WB7204-058	WB7204-A-058	18"	3'6"
WB7205-058	WB7205-A-058	20"	3'10"
WB7206-058	WB7206-A-058	22"	4'2"
WB7207-058	WB7207-A-058	24"	4'6"
WB7208-058	WB7208-A-058	26"	4'10"
WB7209-058	WB7209-A-058	28"	5'2"
WB7210-058	WB7210-A-058	30"	5'6"
WB7211-058	WB7211-A-058	32"	5'10"
WB7212-058	WB7212-A-058	34"	6'2"
WB7213-058	WB7213-A-058	36"	6'6"

Maximum sash weight: 26 lbs.



**WB7200 Series-Non Tilt
Insulating Glass**

BLAINE SERVICE & SUPPLY

TAPE BALANCES / ANDERSEN PERMASHIELD

CALDWELL

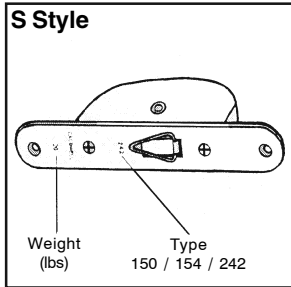
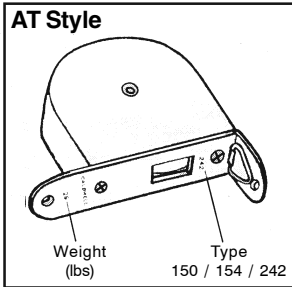
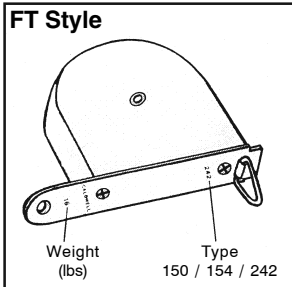

Weight factor based on one (1) pair

Acme - Duplex Tape Balances also available. Please inquire.

HOW TO ORDER:

1. Identify style by above drawings: FT, AT or S.
2. Identify type (type number will be stamped on the face plate).
In some cases, you may need to scrape off paint or dirt to locate the type number.
3. Identify weight (weight number will be stamped on the face plate).
4. Measure tape travel (length) for new or replacement tape balance.

Other Caldwell sash balances, not described on this page, have been developed for specific purposes, special windows or other devices and can be special ordered. Please send samples, or details, to our Customer Service Department.

Face Plate Length					
FT Style		AT Style		S Style	
150-FT	5-1/8"	150-AT	4-11/16"	150-S	6"
154-FT	5-13/16"	154-AT	5-15/32"	154-S	7"
242-FT	4-11/16"	242-AT	4-5/16"	242-S	5-5/8"

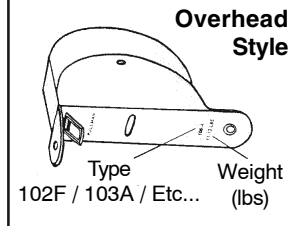
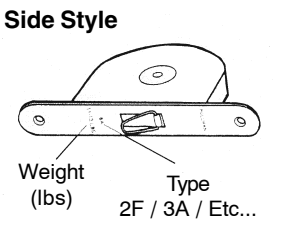

Face Plate Length			
Side Style		Overhead Style	
F	4-3/8"	F	3-3/8"
A	6"	A	4-11/16"
L	7-7/16"	L	5-7/8"
M	8-3/4"	M	7-1/4"

Weight factor based on one (1) pair

HOW TO ORDER:

1. Identify style by above drawings: Side Style or Overhead Style.
2. Identify type (type number will be stamped on the face plate).
In some cases, you may need to scrape off paint or dirt to locate the type number.
3. Identify weight (weight number will be stamped on the face plate).
4. Measure tape travel (length) for new or replacement tape balance.



PERMA-SHIELD or PRIMED NARROWLINE® WINDOWS
Replacement Counter Balances

PART NO. 07489

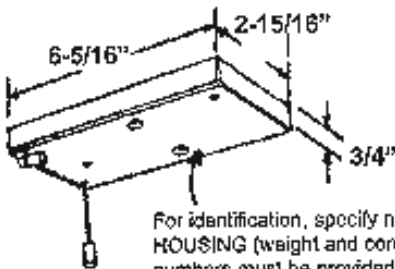

For identification, specify numbers ON HOUSING (weight and cord travel). These numbers must be provided when ordering.

BLAINE SERVICE & SUPPLY

SASH PULLEYS / CONSTANT FORCE BALANCE



Constructed with solid brass, 1/8" thick face plate, ball bearing solid brass wheel, & stamped steel housing.

Model	Face Plate Width	Face Plate Length	Mount Hole Centers
00571-A	1.250" (1-1/4")	6.390"(6-25/34")	5.187" (5-3/16")
00571-B	1.250" (1-1/4")	5.578" (5-37/64")	4.500" (4-3/8")
00571-C	1.125" (1-1/8")	5.437"(5-7/16")	4.375" (4-3/8")
00571-D	1.093" (1-3/32")	4.937"(4-15/16")	4.000" (4")

Constructed with cast housing and wheel, steel axle and operating with chain or rope. Available in red bronze and nickel bronze.

	Face Size	Wheel Diameter	Sash Weight	'A' Dimension	'B' Dimension
00571-A	1-1/4" x 6-1/2"	3"	50-200 lbs.	2-1/4"	5-3/16"
00571-B	1-1/4" x 5-3/4"	2-1/2"	30-50 lbs.	2"	4-1/2"
00571-C	1-1/8" x 5-1/2"	2"	20-40 lbs.	1-3/4"	4-3/8"
00571-D	1" x 5"	2-1/4"	20-40 lbs.	1-5/8"	4"
00571-E	1" x 4-5/8"	2"	1-20 lbs.	1-1/2"	3-5/8"

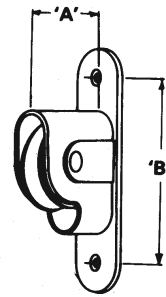

Sash Weights

- 00571-WT-1-1/2-051
2-1/2" high
- 00571-WT-2-051
3-1/4" high
- 00571-WT-8-051
15-1/2" high

- Available in 1-1/2 lb, 2 lbs & 8 lbs
- Designed to be stacked in combination to achieve desired weight.



Sash Chain

01532-Chain

- Copper dipped steel
- 100 ft. in box
- Max. work load - 75 lbs.

Sash fixtures, shown below, sold separately



Sash Fixtures

01532-Fixtures*



- All 1532-Fixtures are packed with 25 sets per box - enough to repair 25 windows.
- 25 sets = 100 ea. hooks & 100 ea. spirals
- *fixtures only work with sash chain, sold separately.

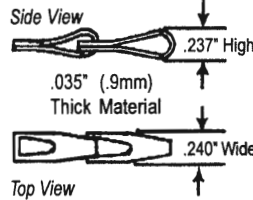

01532-Cord

- Nylon sash cord #7
- 7/32" Nylon
- 100 ft. in box

Single or Double Coil	No. Stamped on Coil	Blaine Part No.
Single	5 or 540	WB9200-Single - 5/540
Single	6 or 640	WB9200-Single - 6/640
Single	7 or 740	WB9200-Single - 7/740
Single	8 or 840	WB9200-Single - 8/840
Single	832	WB9200-Single - 832
Double	440 / 440	WB9200-Dbl - 440/440
Double	440 / 540	WB9200-Dbl - 440/540
Double	540 / 540	WB9200-Dbl - 540 / 540
Double	540 / 640	WB9200-Dbl - 540 / 640
Double	640 / 640	WB9200-Dbl - 640/640
Double	740 / 740	WB9200-Dbl - 740/740

WB9200 Constant Force Balance

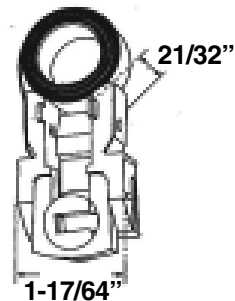

BLAINE SERVICE & SUPPLY

TILT LATCHES

<p>WL0001-L/R</p> <p>Colors: black, cocoa, 3-3/8" white</p> <p>Obsolete. Order WL-1</p>	<p>WL0002-L/R</p> <p>Available in black & white</p>	<p>WL0003-L/R</p> <p>L/R PAIR Black or white</p>
<p>WL0005 Acorn</p> <p>Sold Each</p> <p>Black</p>	<p>WL0006-L/R Quaker</p> <p>L/R PAIR</p> <p>Black & white</p>	<p>WL0007-L/R ACORN WINDOWS & DOORS</p> <p>L/R PAIR Black</p> <p>Black only</p>
<p>WL0008-L/R</p>	<p>WL0009-L/R Reynolds Black only</p>	<p>WL0015 Zinc cast replacement</p>
<p>WL0016</p> <p>Available in black & white</p>	<p>WL0017-L/R Reynolds</p>	<p>WL0019-L/R</p>



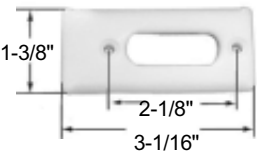
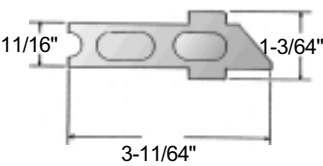
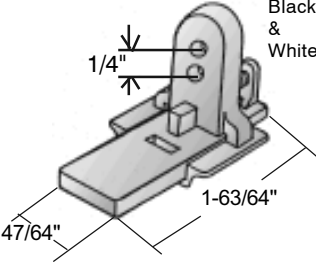
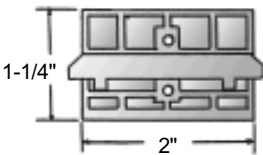
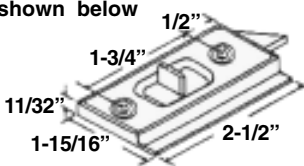
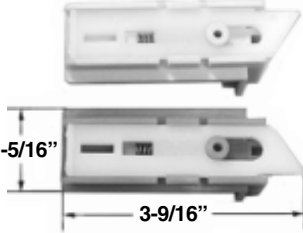
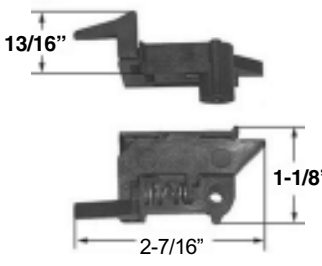
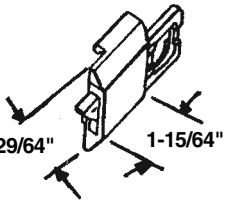
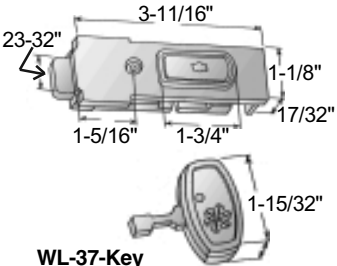
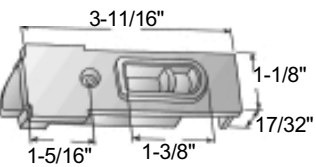
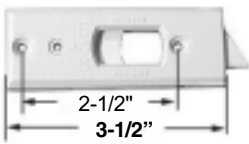
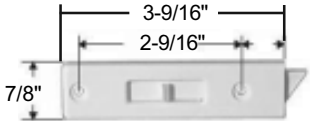
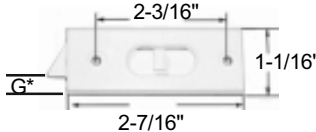

BLAINE SERVICE & SUPPLY

TILT LATCHES

<p>WL0020</p> <p>Sold Each</p>  <p>Available in black or white</p> <p>For inside latch, order WL0023</p>	<p>WL0027</p> <p>Zinc Cast Replacement with springs</p> 	<p>WL0029-L/R</p>  <p>Black & White</p>
<p>WL0030-New-L/R</p>  <p>OBSOLETE - L/R Replacement shown below</p> 	<p>WL0031-L/R White</p>  <p>For thumb grip, order WL-31-Gripper</p>	<p>WL0032-L/R Acorn Black</p> 
<p>WL0033-L/R</p> <p>L/R PAIR Keller</p> 	<p>WL0037 Black</p>  <p>WL-37-Key</p>	<p>WL0038-L/R Black</p> 
<p>WL0039 White</p> 	<p>WL0044-A, C</p>  <p>A = w/o Latch Lock, w/ Flat Bottom C = w/ Latch Lock, w/ Flat Bottom</p> <p>Sold as pair</p>	<p>WL0046/WL0047-L/R White</p>  <p>Sold Pair</p> <p>*WL-46 - G = 19/64" *WL-47 - G = .305"</p>

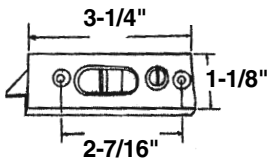
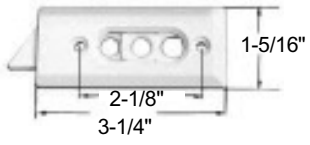
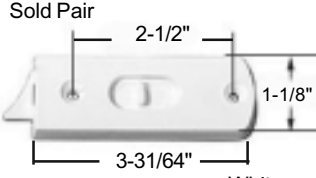
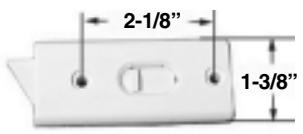
BLAINE SERVICE & SUPPLY

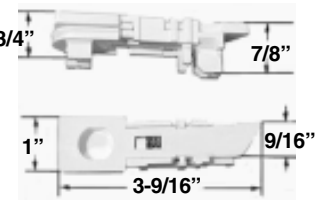
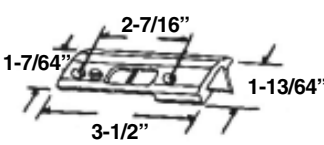
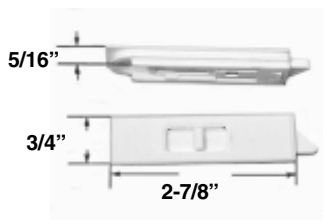
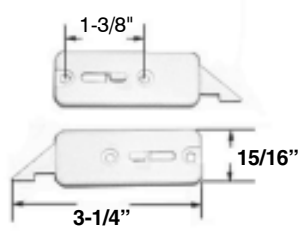
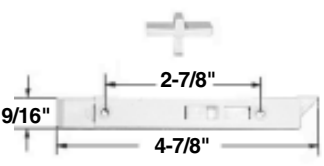
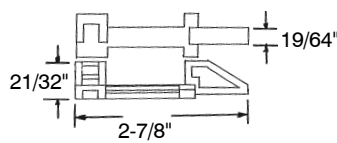
TILT LATCHES

<p>WL0048-L/R</p> <p>black or white</p>  <p>Sold as pair</p>	<p>WL0050-A</p> <p>Sold Pair White</p>  <p>WL-50-A* w/ Flat Bottom</p>	<p>WL0054-A-L/R-067 WL0054-B-L/R-067</p> <p>Sold Pair</p>  <p>White</p> <p>WL-54A* w/ .125" Bottom Hole Post, w/o Lock</p> <p>WL-54B* w/ flat Bottom, w/o Lock</p>
<p>WL0061* WL0064*</p> <p>Sold Pair White</p>  <p>WL-61* w/ Flat Bottom, w/ 3/16" Latch Height</p> <p>WL-64* w/ 11/32" Bottom Hole Post, w/ 3/16" Latch Height</p>	<p>WL0065-L/R</p>  <p>Beige</p>	<p>WL0067-L/R</p> <p>White</p> 
<p>WL0097</p> <p>Black</p>  <p>Left / Right Pair</p>	<p>WL0104-L</p> <p>LH shown</p>  <p>white</p> <p>Sold Each Left hand Shown. For Right Hand, order WL0104-R</p>	<p>WL0112-L/R</p>  <p>Black or white</p>
<p>WL0120</p> <p>White</p>  <p>Sold as pair</p>	<p>WL0138</p>  <p>L/R Pair Cast Zinc Replacement</p>	<p>004429- L/R</p> <p>Sold L/R Pair</p>  <p>Available in black or white</p> <p>2 pc nylon w/ compression spring</p>

GP-54

Phone: (708) 343-8800

Fax: (855) 898-6471

BLAINE SERVICE & SUPPLY







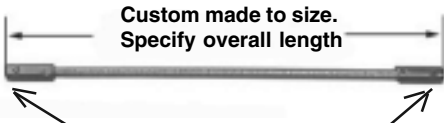
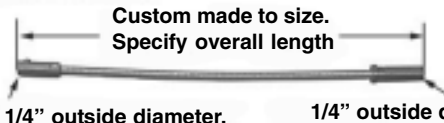
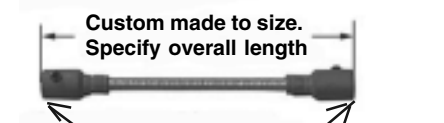

Sold As Pair

PRESSURE SHOES AND ACCESSORIES

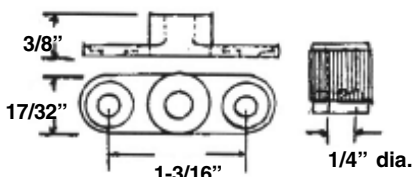
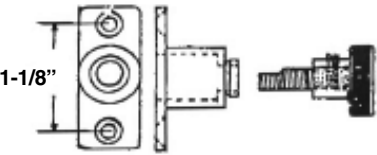
<p>P0071-L/R-Long Cast zinc replaces original aluminum. Comes with set screw.</p> <p>3-7/64" 1-5/8" 41/64" 1-1/32" .453" I.D. (For 7/16" dia. shoe pin)</p>	<p>P0207-L/R</p> <p>1-5/32" 9/32" hole 3/4" 1-65/64" 3/8"</p> <p>L/R Pair Set Screws Included</p>	<p>P0341-054</p> <p>10.24 tapped holes 5/8" 7/8" 7/8" 7/8" 2-13/16" 5/16" dia. hole</p>
<p>P0356 / 357-054</p> <p>1-5/8" 5/16" 9/16" 1" 13/16" 1-1/16" 1-1/2" 3-9/16"</p> <p>For nylon shoe & pin only, order P0060-Orig-058</p>	<p>P0035</p> <p>5/16" 1-3/4" 1/2"</p>	<p>P0070-L/R</p> <p>3/8" dia. 1-3/8" 1-1/32" 3/8" Ht.</p>
<p>P0081</p> <p>2" 5/16" diameter</p>	<p>P0086 L/R Pair</p> <p>3/8" 1-51/64" 5/8" 1-23/64" 2"</p> <p>Nylon with aluminum pin</p>	<p>P0120</p> <p>1/8" .020 wire dia. 1-7/8"</p>
<p>P0171-L/R Sold as pair Kawneer</p> <p>2-17/64" 57/64" 3/8" dia. pin</p> <p>For brkt w/ arm, order P0171-2-050</p>	<p>P0201-L/R Sold as pair</p> <p>5/16" dia. 1-19/64" 11/32" 1-1/4"</p>	<p>P0273</p> <p>.055" wire dia. 1/4" 2"</p>
<p>P0277</p> <p>5/16" dia. 1-13/64" 13/32" Ht. 1-1/4"</p>	<p>P0311</p> <p>5/16" .045 wire dia. 1-1/8"</p>	<p>P0395-L/R</p> <p>1-3/4" 1-5/16" 2-17/32" (10) piece assembly</p>

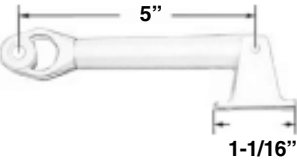
BLAINE SERVICE & SUPPLY

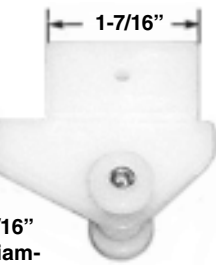
VENETIAN BLIND / DRAPERY HARDWARE

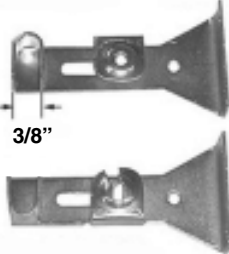
<p>VB0020</p>  <p>Custom made to size. Specify overall length</p> <p>1/4" outside diameter. .152 Inside diameter. Both ends</p>	<p>VB0021</p>  <p>Custom made to size. Specify overall length</p> <p>1/4" outside diameter. 1/4" outside dia. .152 Inside diameter.</p>	
<p>VB0022</p>  <p>Custom made to size. Specify overall length</p> <p>.365" outside diameter. .225" Hex hole. Both ends</p>	<p>VB0043</p>  <p>6-5/16"</p> <p>1-1/8"</p>	
<p>VB0049</p>  <p>3/8"</p> <p>17/32"</p> <p>1-3/16"</p> <p>1/4" dia.</p> <p>Cast zinc replacement (orig. was black nylon)</p>	<p>VB0063-Knob/Base</p>  <p>1-1/8"</p> <p>Cast zinc metal replacement black finish</p>	
<p>DR0003</p>  <p>7/16"</p>	<p>DR0020</p>  <p>5"</p> <p>1-1/16"</p>	<p>DR0022</p>  <p>1/2"</p>
<p>DR0041</p>  <p>1-7/16"</p> <p>7/16" diameter</p>	<p>DR0042</p> <p>Sold with or without rollers</p>  <p>4-37/64"</p> <p>7/16" diameter wheel</p>	<p>DR0060-L/R Steel</p>  <p>3/8"</p> <p>Sold L/R</p>

BLAINE SERVICE & SUPPLY

Sold As Pair

CORNER KEYS / TILT KEYS

<p>CK0023</p>	<p>CK0028</p>	<p>CK0065</p>
<p>CK0094</p> <p>Black, Gray or White</p>	<p>CK0098</p> <p>Bronze, Champagne or White</p>	<p>CK0189</p>
<p>TK0012</p>	<p>TK0016</p>	<p>TK0023</p>
<p>TK0039</p>	<p>TK0046</p>	<p>TK0049</p>
<p>TK0054</p>	<p>TK0057</p>	<p>TK0062</p>

BLAINE SERVICE & SUPPLY

Sold As Pair

SLIDEBOLTS

<p>SB0005</p>	<p>SB0006</p>	<p>SB00019 White</p>
<p>SB0021</p>	<p>SB0024</p>	<p>SB0029 Set</p>
<p>SB0032</p>	<p>SB0034 Nylon</p>	<p>SB0061</p>
<p>SB0077</p>	<p>SB0092</p>	<p>SB0105</p>
<p>SB0129</p>	<p>SB0155</p> <p>Cast Zinc Replacement</p>	<p>SB0210</p> <p>Cast Zinc</p>

GP-58

Phone: (708) 343-8800

Fax: (855) 898-6471

BLAINE SERVICE & SUPPLY

SCREEN CORNERS

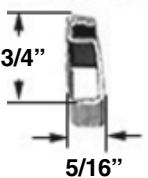
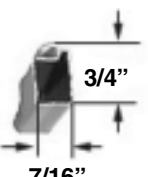
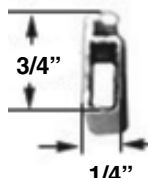
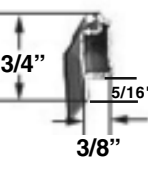
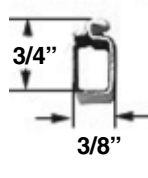
 <p>3/4" 5/16"</p>	<p>5/16" X 3/4" 91007-Almond-8'-20pc* 91007-Bronze-8'-20pc* 91007-Mill-8'-20pc* 91007-White-8'-20pc*</p>		<p>Nylon Sold Ea. 91007-CR</p>		<p>91207-CR-Almond 91207-CR-Bronze 91207-CR-Gray 91207-CR-White Nylon Sold Ea.</p>
 <p>3/4" 7/16"</p>	<p>7/16" X 3/4" 91016-Almond-8'-20pc* 91016-Bronze-8'-20pc* 91016-Mill-8'-20pc* 91016-White-8'-20pc*</p>		<p>Nylon Sold Ea. 91016-CR</p>		<p>91216-CR-Almond 91216-CR-Bronze 91216-CR-Gray 91216-CR-White Nylon Sold Ea.</p>
 <p>3/4" 1/4"</p>	<p>1/4" X 3/4" 91021-Almond-8'-20pc* 91021-Bronze-8'-20pc* 91021-Mill-8'-20pc* 91021-White-8'-20pc*</p>		<p>Nylon Sold Ea. 91021-CR</p>		<p>91221-CR-Bronze 91221-CR-Gray 91221-CR-White Nylon Sold Ea.</p>
 <p>3/4" 5/16" 3/8"</p>	<p>3/8" X 3/4" 91052-Almond-8'-20pc* 91052-Bronze-8'-20pc* 91052-Mill-8'-20pc* 91052-White-8'-20pc*</p>		<p>Nylon Sold Ea. 91088-CR</p>	<p>All roll formed frames are sold in 8 ft. lengths, packed 20 per tube.</p>	
 <p>3/4" 3/8"</p>	<p>3/8" X 3/4" 91088-Almond-8'-20pc* 91088-Bronze-8'-20pc* 91088-Mill-8'-20pc* 91088-White-8'-20pc*</p>		<p>Nylon Sold Ea. 91088-CR</p>		<p>91288-CR-Almond 91288-CR-Bronze 91288-CR-Gray 91288-CR-White Nylon Sold Ea.</p>



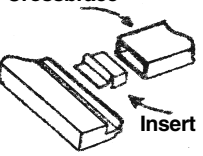
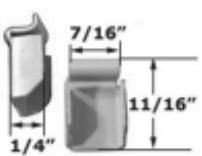

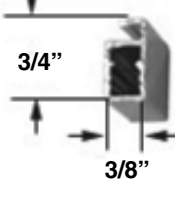
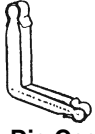









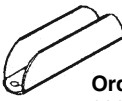

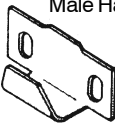
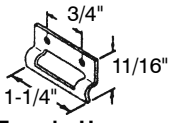
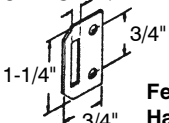
Order 91301-Insert-040 for spreader bar.

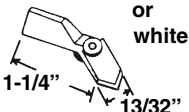
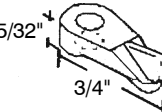
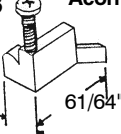
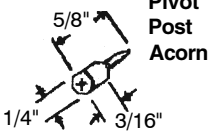
<p>Crossbrace</p>  <p>Insert</p>	<p>(2) needed per bar.</p> <table border="1"> <thead> <tr> <th>Crossbrace Insert</th> </tr> </thead> <tbody> <tr> <td>91301-Insert-040</td> </tr> </tbody> </table> <p>Fits 5/16" X 5/8" Crossbrace</p>	Crossbrace Insert	91301-Insert-040	 <p>7/16" 11/16" 1/4"</p>	<table border="1"> <thead> <tr> <th>Crossbrace</th> </tr> </thead> <tbody> <tr> <td>91301-Almond-8'-20pc</td> </tr> <tr> <td>91301-Bronze-8'-20pc</td> </tr> <tr> <td>91301-Mill-8'-20pc</td> </tr> <tr> <td>91301-White-8'-20pc</td> </tr> </tbody> </table>	Crossbrace	91301-Almond-8'-20pc	91301-Bronze-8'-20pc	91301-Mill-8'-20pc	91301-White-8'-20pc
Crossbrace Insert										
91301-Insert-040										
Crossbrace										
91301-Almond-8'-20pc										
91301-Bronze-8'-20pc										
91301-Mill-8'-20pc										
91301-White-8'-20pc										

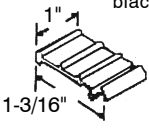
<p>Available in 8' lengths</p>  <p>3/4" 3/8"</p>	<p>3/8" X 3/4" 91003-8'-Black 91003-8'-Bronze 91003-8'-White</p> <p>Superior strength and rigidity for commercial and institutional use.</p>	<p>Internal Mitred Corner</p> <p>91003-CR</p>  <p>Die Cast</p> <table border="1"> <tbody> <tr> <td>Die Cast Mitred Corner</td> </tr> <tr> <td>91003-CR</td> </tr> </tbody> </table>	Die Cast Mitred Corner	91003-CR	<p>5/16" x 5/8" Crossbrace</p> <p>SS-140 spline recommended for all Blaine screen frames.</p> <p>If spreader bar (crossbrace - 5/16" x 5/8" x 8') needed, order 91301 in Mill, White, Bronze or Almond.</p>
Die Cast Mitred Corner					
91003-CR					

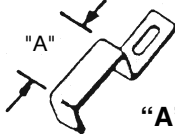
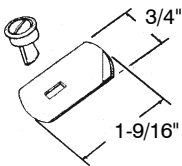
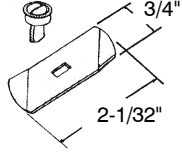
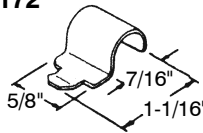
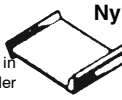
BLAINE SERVICE & SUPPLY

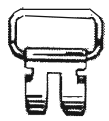
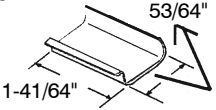
SCREEN HARDWARE

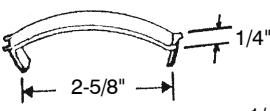
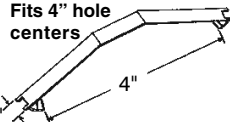
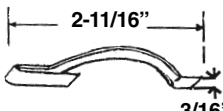
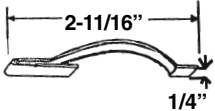
<p>01116</p>  <p>3/8"</p> <p>Slide Latch</p>	<p>01131</p>  <p>5/8"</p> <p>Slide Latch</p>	<p>02285</p>  <p>Specify Handing- Right Hand Shown</p> <p>Knife Latch</p>	<p>08900-L/R</p>  <p>Andersen</p>
<p>04445</p>  <p>Sold L/R Pair</p> <p>Swivel Latch</p>	<p>01123</p>  <p>5/16"</p> <p>Order 2288, at right</p> <p>Friction Hanger</p>	<p>02263</p>  <p>7/16"</p> <p>Friction Hanger</p>	<p>02288</p>  <p>3/8"</p> <p>Friction Hanger</p>
<p>08899</p>  <p>Male Hanger</p>	<p>01126</p>  <p>3/4" 11/16" 1-1/4"</p> <p>Female Hanger</p>	<p>02245</p>  <p>3/16" 3/4" 1-1/4" 3/4"</p> <p>Female Hanger</p>	<p>01117</p>  <p>1" 1/2" 3/8"</p> <p>Male Hanger</p>
<p>08800</p>  <p>Nylon</p> <p>Black or White</p>	<p>20284</p>  <p>black or white</p> <p>1-1/4" 13/32"</p>	<p>20023</p>  <p>Clear or white</p> <p>5/32" 3/4"</p>	<p>08808</p>  <p>Acorn</p> <p>Black or white</p> <p>35/64" 61/64"</p>
<p>08809</p>  <p>Screen Pivot Post Acorn</p> <p>5/8" 3/16" 1/4"</p>	<p>Cee Clips</p>  <p>"A"</p>	<p>20161</p>  <p>black</p> <p>1" 1-3/16"</p>	<p>20561-058</p>  <p>1-3/16"</p> <p>Screen Clip</p>
<p>Stretcher Clips</p>  <p>"A"</p> <p>"A"</p> <p>01186 3/4" 02261 1" 01143 11/16"</p>	<p>"A"</p> <p>08915 1/4" 01166 5/16" 01144 3/8" 01165 7/16"</p>	<p>Storm /Screen Latch For Wood</p> <p>04499-Single</p>  <p>3/4" 1-9/16"</p> <p>04499-Double</p>  <p>3/4" 2-1/32"</p>	
<p>01172</p>  <p>7/16" 5/8" 1-1/16"</p> <p>Miami Screen Clip</p>	<p>02274</p>  <p>Flexible Nylon</p> <p>Available in Black. Order 20164 for Black & Clear</p> <p>1" Nylon Lift</p>	<p>Latch to fasten wood storm or screen inserts into a combination door or window frame.</p>	
<p>01122</p>  <p>Clip & Screw</p> <p>1122-1 Ball head screw only</p>	<p>08901</p>  <p>Andersen</p>	<p>04411</p>  <p>53/64" 1-41/64"</p>	<p>02212</p>  <p>Frame Tension Spring</p>
<p>02216</p>  <p>2-5/8" 1/4"</p> <p>Frame Tension Springs</p> <p>Fits 4" hole centers</p> <p>01142</p>  <p>1/4" 4"</p>	<p>20004-Narrow</p>  <p>2-11/16" 3/16"</p>	<p>20004</p>  <p>2-11/16" 1/4"</p>	

BLAINE SERVICE & SUPPLY

SCREEN HARDWARE / SCREENS

01125

Nylon

W/ Spring Black or White

Use Step Drill #S0025

7/32" 3/4" 5/16"

04474 All Metal

5/8" 7/32" 23/64" 11/16"

04495

Metal Plunger 5/32" Nylon Knob 27/64"

Plain Plastic Screen Clips

"A"

M-8950	Flush
M-8951	1/16"
M-8952*	3/16"
M-8956*	1/4"
M-8953	5/16"
M-8954	3/8"
M-8955	7/16"

White, Black or Gray

*M-8952 white only
*M-8956 Black or white only

PLAIN DIE CAST SCREEN CLIPS

"A" Gray

08931	Flush
04467	1/16"
08868	3/16"
04428	1/4"
01124	5/16"
02206	3/8"
01120	7/16"
01153	1"
01153-1-1/8	1-1/8"

Universal Adjustable Clips

Gray "A"

Part No.	Mat'l	"A"
01152	Nylon	Flush
04443	Nylon	1/8"
01151	Nylon	9/32"
20058	Nylon	7/16"
20059*	Nylon	19/32"
02239	Nylon	3/4"
20060	Nylon	13/16"

All clips, shown here, furnished with 1151-1 (10-24 x 13/16") smooth shank machine screws. Springs included where applicable. For extra screws or optional sizes, order:
1151-1 (10-24 x 13/16" machine screw), 1151-2 (#8 X 1-1/4" wood screw), 1151-3 (10-32 x 13/16 machine screw), 1151-4 (spring).

*Limited surplus of diecast still available

Screen Worksheets Available By Contacting Our Screen Department

Many Screen Styles & Sizes Not Shown Here Available. Please Inquire!

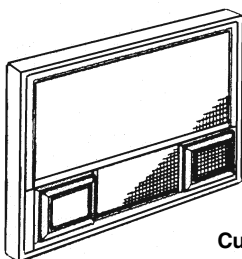

SLIDING WICKET

Custom screen orders require a minimum of (6) screens in any combination.

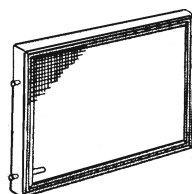

FIXED & HOPPER

HINGED WICKET

HANDED

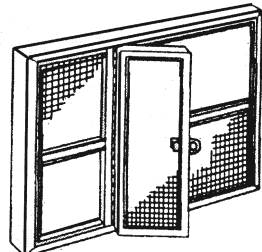

BLAINE SERVICE & SUPPLY

CUSTOM SCREENS / PET SCREENS / SCREEN TOOLS

For casement or awning
window screens

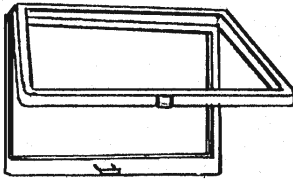

- Easy access to operator or handle
- Hinges a full 180 degrees
- Install your own matching wire
- Pop rivets to screen frame
- Easy snap closure latch

Dimensions:
Top width: 8-1/2"
Bottom width: 10-1/8"
Height: 6-1/8"

PLASTIC WICKETS

Part No.	Color
91001-Gray	Gray
91001-Bronze	Bronze
91001-White	White



Introducing...

*Colors Available: Black, Gray
Widths Available: 30", 36", 48", 60"
Roll Length Available: 100'

SWPS30-Black
SWPS30-Gray
SWPS36-Black
SWPS36-Gray
SWPS48-Black
SWPS48-Gray
SWPS60-Black
SWPS60-Gray

Pet Resistant Insect Screening

- Resists damage by dogs & cats
- Excellent outward visibility
- Made of strong vinyl-coated polyester
- Easy to install



Call us for FREE sample!

TOOLS

Note: All prices, appearing in this flyer, are subject to change without notice.

S003A

Screen Cloth-Spline Roller

Step
Roller



Wood Handle
Steel Roller

S0005

Screen Cloth-Spline Roller

1/16"
rounded
roller

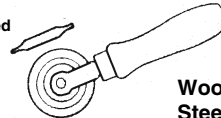

Wood Handle
Steel Roller

S0006

Retractable Utility Knife - Metal

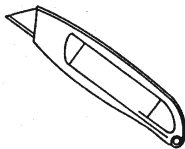

M01201-N-5/8

Economy Plastic
Spline Roller

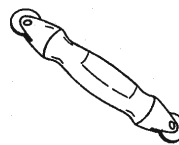

S0011

Notching Tool



S0012

Notching Tool
Jig Assembly

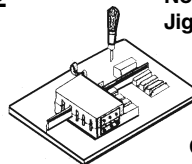

Comes with S-11,
as shown

S0023

Plunger Latch Jig

- Will not scratch frame
- Produces clean, straight holes
- Convenient & easy
- Use w/ S-25

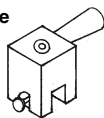

Nylon

S0025

Step Drill



For plunger with to 1/8" to
7/32" tip

GP-62

Phone: (708) 343-8800

Fax: (855) 898-6471

BLAINE SERVICE & SUPPLY

GLAZING CHANNEL / GLAZING BEAD

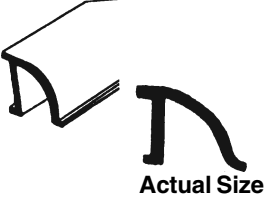
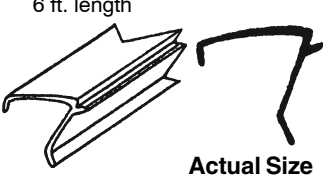
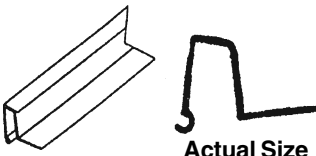
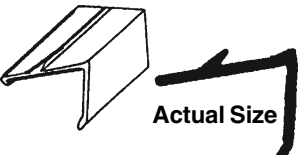
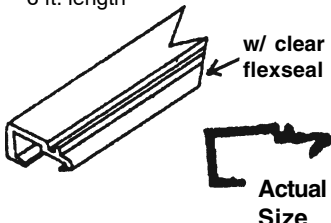
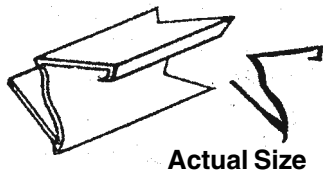
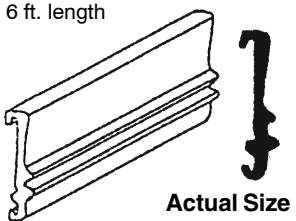
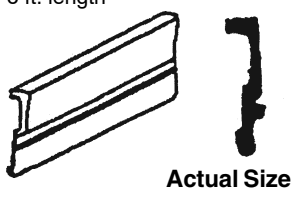
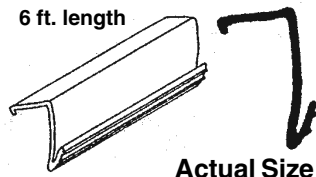
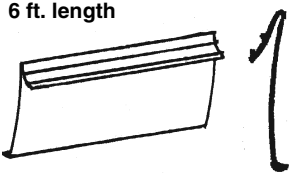
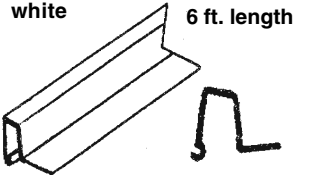
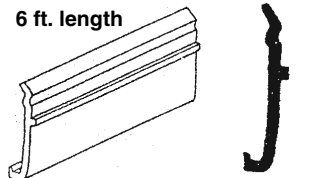
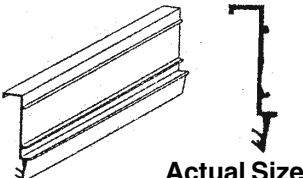
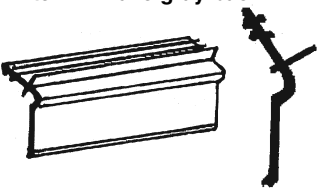
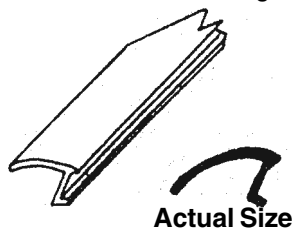
<p>GS0015 Black, Gray or White 6 ft. length</p>  <p>Actual Size</p>	<p>GS0031 Available in Bronze or white 6 ft. length</p>  <p>Actual Size</p>	<p>GS0032 Available in Bronze or white 6 ft. length</p>  <p>Actual Size</p>
<p>GS0036 Available in White 6 ft. length Dual Durometer</p>  <p>Actual Size</p>	<p>GS0043 Available in bronze or white 6 ft. length w/ clear flexseal</p>  <p>Actual Size</p>	<p>GS0052 6 ft. length</p>  <p>Actual Size</p> <p>Available in black or white</p>
<p>GS0056 Available in Black 6 ft. length</p>  <p>Actual Size</p>	<p>GS0060 Available in Bronze or White 6 ft. length</p>  <p>Actual Size</p>	<p>GS0102 Available in almond or white 6 ft. length</p>  <p>Actual Size</p>
<p>GS0107 Available in black or white 6 ft. length</p>  <p>Actual Size</p>	<p>GS0113 Available in bronze or white 6 ft. length</p>  <p>Actual Size</p>	<p>GS0120 6 ft. length</p>  <p>Actual Size</p> <p>Available in bronze or white</p>
<p>GS0136 6 ft. length Available in black or white</p>  <p>Actual Size</p>	<p>GS0158 4 ft. or 8 ft. length Available in brown, sandstone or white. All have gray back.</p>  <p>Actual Size</p>	<p>GS0886 6 ft. length</p>  <p>Actual Size</p> <p>Available in Lt. Gray or white</p>

BLAINE SERVICE & SUPPLY

Patio Door Track / Screen Door Grilles / Weatherstripping

T0001

Replacement Patio Door Sill Track Cover

- Fits most track doors
- Easy to install
- Quickly replaces damaged track
- Saves time and money
- Attractive replacement for damaged or corroded track
- Available in 6 ft. & 8 ft. length

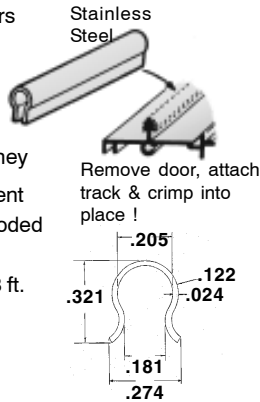

T0003

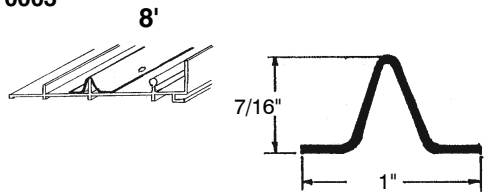

T0006 Threshold Replacements for Sliding Glass And Screen Doors

Available in 6 ft. & 8 ft. lengths

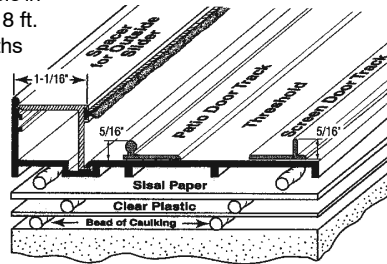

T0007

For Glass Doors

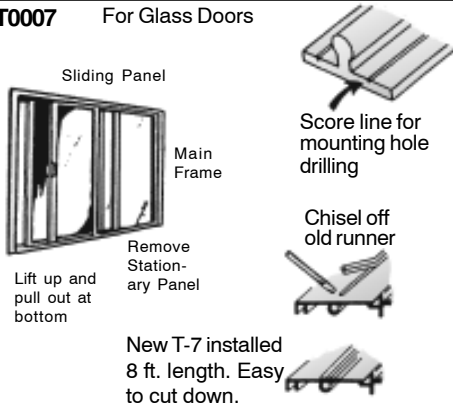

T0009

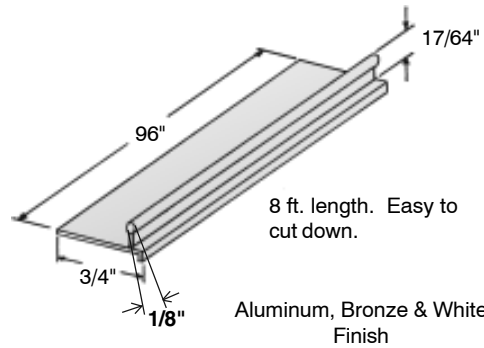

Brush Style Weatherstripping

SD0238

Specially designed to stop air, water dust and insects from entering. Silicone treated pile will not shrink, rot or absorb water and low friction sealing action allows for minimum drag during opening and closing. Can be installed around doors on top and side jamb stops where air infiltration is a particular problem. Available in aluminum and bronze finish.



Available in 3', 6' and 12' lengths

- Attractive & Functional
- Easy To Install

Sliding Screen Door Grilles

- Sizes To Fit 28-1/4" - 49-1/4" W Doors

Made of heavy duty aluminum and strong enough to protect doors from the abuse of children and pets. These grilles save time and money by eliminating the need to constantly repair screen doors.

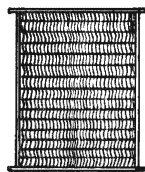

- PSD 1014** 28-1/4" - 31-1/4"
- PSD 1015** 34-1/4" - 37-1/4"
- PSD 1016** 46-1/4" - 49-1/4"

DRAFT-SEAL WEATHERSTRIPPING

Polypropylene Backing Resists Shrinkage

	A		B		C	
	In	mm	In	mm	In	mm
WS-7	.187	4.7	.150	4.0	.035	0.9
WS-8	.187	4.7	.190	4.0	.035	0.9
WS-9	.187	4.7	.250	6.7	.035	0.9
WS-15	.229	5.9	.260	6.7	.035	0.9
WS-16	.229	5.9	.310	7.9	.035	0.9
WS-22	.270	6.9	.170	4.0	.035	0.9
WS-24	.270	6.9	.250	6.5	.035	0.9
WS-25	.270	6.9	.310	7.9	.035	0.9
WS-26	.270	6.9	.360	9.0	.035	0.9

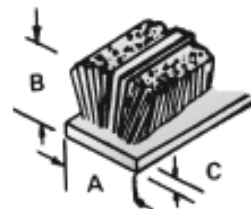







Reduces Air Infiltration
Resists Shrinkage
Exceeds AAMA Specifications

GP-64

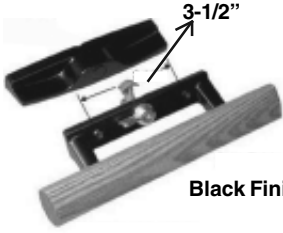
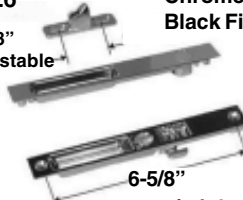
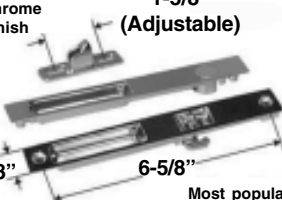
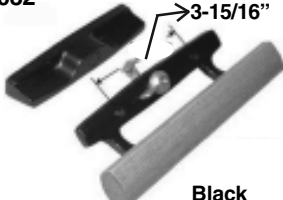
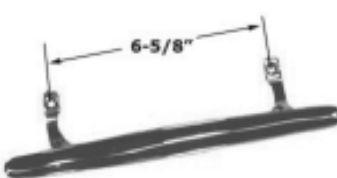
Phone: (708) 343-8800 Fax: (855) 898-6471





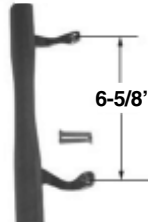
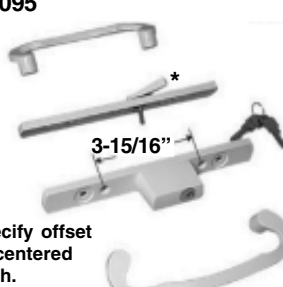
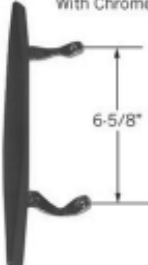





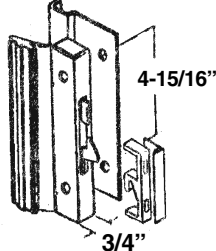
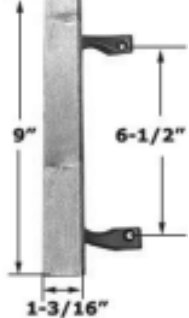

BLAINE SERVICE & SUPPLY

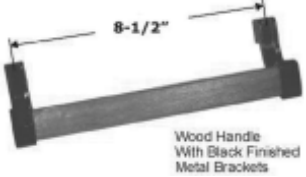
PATIO DOOR HANDLES

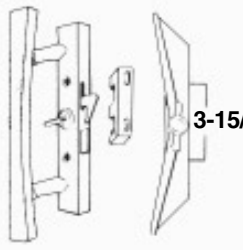
<p>H0009</p>  <p>3-1/2"</p> <p>Black Finish</p>	<p>H0026 Chrome or Black Finish</p>  <p>1-5/8" adjustable</p> <p>6-5/8"</p> <p>w/ night latch</p> <p>For optional pull handle for extra grip, order H0096-030</p> <p>Most popular flush mount keyed set used by most door manufacturers</p>	<p>H0027 Chrome Finish</p>  <p>1-5/8" (Adjustable)</p> <p>7/8" 6-5/8"</p> <p>For optional pull handle for extra grip, order H0096-030</p> <p>Most popular flush mount set used by most door manufacturers</p>
<p>H0032</p>  <p>3-15/16"</p> <p>Black Finish</p>	<p>H0025</p>  <p>6-5/8"</p> <p>Bright Chrome</p>	<p>H0041 Howard</p>  <p>5-1/2"</p> <p>For Keyed Version Order: H0041-w/KEY-072 Blaine Heavy Duty Version (Solid Foundry Cast Aluminum) With Black Texture Finish</p> <p>Heavy Duty Also Available w/o Key Order: H0041-072</p>
<p>H0053 Ador / Hilite</p>  <p>H0053 ADOR/HILITE</p> <p>3-7/8"</p> <p>For Pull W/Key Order H0053-KEY For Flip Latch Repair Kit Order H0053-1 For Outside Pull Only Order H0053-2</p>	<p>H0054 For 1" thick doors</p>  <p>Chrome Finish</p> <p>6-1/2"</p> <p>For keyed version order H0054-030-w/ key</p> <p>For extra key cylinders only order H0054-Key-050</p> <p>For 7/8" thick doors order H0054-A-030</p> <p>For optional inside pull handle for extra grip order H0056-030</p>	<p>H0056</p>  <p>6-5/8" Wood Handle Can Be Cut Down To Accommodate A Center To Center Hole Spacing As Low As 3/4"</p> <p>Wood Handle With Black Finished Metal Brackets (Handle Subject To Change To Wood Grained Or Black Textured Metal Depending Upon Availability, But Can Still Be Cut Down</p>
<p>H0059</p>  <p>3-15/16"</p>	<p>H0062 Tucker</p>  <p>Dull Aluminum Finish</p> <p>5"</p> <p>LH Shown. Specify Left or Right Hand</p>	<p>H0080 Deluxe Wood Handle With Chrome Brackets</p>  <p>6-5/8"</p>
<p>H0095</p>  <p>3-15/16"</p> <p>* Specify offset or centered latch. Offset shown</p>	<p>Fits 1-1/2" Thick Door</p> <p>w/Key order: H0095-1-1/2-003-w/key (brass) H0095-1-1/2-031 w/key (satin chrome) H0095-1-1/2-067-w/key (white)</p> <p>w/o Key order: H0095-1-1/2-003-w/o key (brass) H0095-1-1/2-031 w/o key (satin chrome) H0095-1-1/2-067-w/o key (white)</p> <p>w/Key order: Fits 1-3/4" Thick Door H0095-1-3/4-003-w/key (brass) H0095-1-3/4-031 w/key (satin chrome)</p>	<p>H0096 With Chrome Brackets</p>  <p>6-5/8"</p>

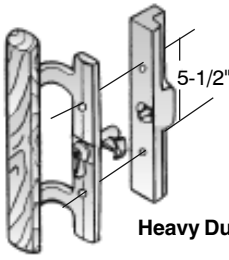

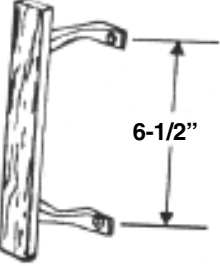







BLAINE SERVICE & SUPPLY

PATIO DOOR HANDLES

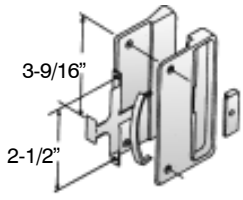
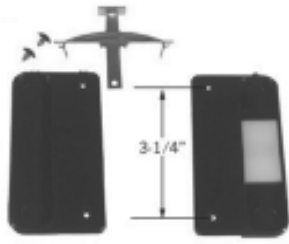
<p>H0101</p>  <p>4-15/16"</p> <p>Comes w/ No. H-110 Outside Handle Comes w/ No. H0101-1 Keeper</p> <p>Surface mount universal style. Adapts to more than 90% of doors</p> <p>Can be used to replace obsolete handle assemblies</p>	<p>H0106</p>  <p>3-1/2"</p> <p>For Key Cylinder, See H0106-KEY</p>	<p>H0140</p>  <p>6-1/2"</p> <p>For handle and key, order H0140-w/key</p>
<p>H0148 Aluminum or Black</p>  <p>4-15/16"</p> <p>3/4"</p>	<p>H0157</p>  <p>9"</p> <p>6-1/2"</p> <p>1-3/16"</p>	<p>H0159</p> <p>Capitol</p>  <p>1-1/8"</p> <p>2"</p>
<p>H0160</p>  <p>8-1/2"</p> <p>Wood Handle With Black Finished Metal Brackets</p>	<p>H0161 - Aluminum</p>  <p>4-15/16"</p>	<p>H0161 - Black</p>  <p>4-15/16"</p> <p>Comes w/ No. H0110 outside handle</p> <p>Clamp lock type</p> <p>Available in aluminum or black finish</p>
<p>H0168</p>  <p>3-15/16"</p>	<p>H0180 Black finish</p>  <p>6-5/8"</p> <p>Complete Assembly With Outside 2-Piece Handle w/ Plate And Keeper</p>	<p>H0298 Replacement for standard duty H-98 which is no longer available</p>  <p>5-1/2"</p> <p>Heavy Duty</p> <p>When ordering complete handle with key cylinder, order H-298-With-Key</p>
<p>H0304</p>  <p>3-15/16"</p> <p>H0304</p> <p>Comes w/ Outside Handle And No. H0304-1-001 Thumb Turn</p> <p>Specify 038 Brown Finish 067 White Finish</p>	<p>H0333</p>  <p>6-1/2"</p>	<p>H0340</p>  <p>5-1/2"</p>

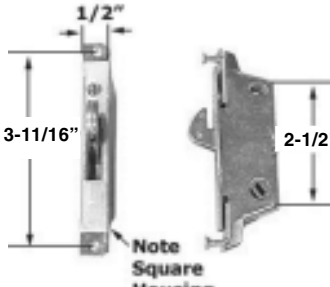
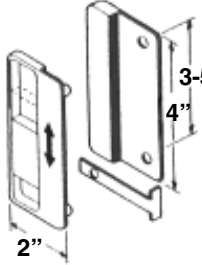
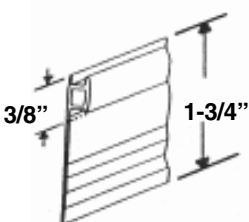
BLAINE SERVICE & SUPPLY

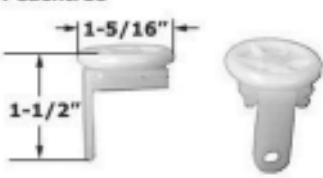
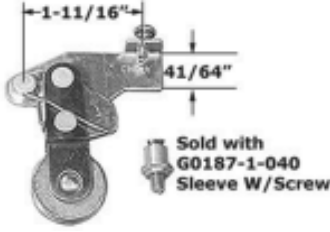
PATIO DOOR HANDLES / LATCHES

<p>40.11</p>  <p>Inside Handle</p> <p>Note: The Color Code is the 5th & 6th Digit of the Part Number</p>	<p>40.12</p>  <p>Outside Handle</p> <p>Note: The Color Code is the 5th & 6th Digit of the Part Number</p>	<p>L0012</p> 
<p>L0019</p> <p>Keller</p>  <p>2-7/8"</p>	<p>L0031</p>  <p>3-9/16"</p> <p>2-1/2"</p>	<p>L0172</p>  <p>3-1/4"</p>
<p>L0240</p> <p>Andersen</p>  <p>5/8"</p> <p>1-1/2"</p> <p>4-1/2"</p> <p>4"</p>	<p>L0302-Square</p>  <p>1/2"</p> <p>3-11/16"</p> <p>2-1/2"</p> <p>Note Square Housing</p>	<p>L0324</p>  <p>3-5/16"</p> <p>4"</p> <p>2"</p>
<p>WS0149</p>  <p>3/8"</p> <p>1-3/4"</p> <p>Can be torn away in 3/16" increments</p>	<p>G0074</p> <p>Crossly</p>  <p>37/64"</p> <p>2-5/32"</p> <p>White Nylon</p> <p>Sold in Pair</p> <p>3/64"</p>	<p>G0084</p> <p>Crossly</p>  <p>19/32"</p> <p>1-55/64"</p> <p>White Nylon Guide</p> <p>Sold in Pair</p>
<p>G0135</p> <p>Peachtree</p>  <p>1-5/16"</p> <p>1-1/2"</p>	<p>G0187</p> <p>Nylon or steel roller</p>  <p>1-11/16"</p> <p>41/64"</p> <p>Sold with G0187-1-040 Sleeve W/Screw</p>	<p>G0219</p>  <p>1"</p> <p>13/32" Thick</p> <p>7/8" Nylon Wheel</p>

BLAINE SERVICE & SUPPLY

PATIO DOOR GUIDES / ROLLERS / KEEPERS

<p>G0226</p> <p>Nylon</p> <p>1" 3-3/8" 15/16"</p>	<p>G0239-058 Nylon G0239-050 Steel</p> <p>Peachtree</p> <p>1-1/8" 1-7/16" 1-13/16"</p> <p>Steel Housing with 1" Diameter Steel Ball Bearing Conclave Roller</p>	<p>G0248 Peachtree</p> <p>Nylon Non-Ball Bearing Roller 1-5/16" Diameter</p> <p>1-13/16" 1-15/16"</p>
<p>R0200</p> <p>The R-200-Kit contains over 160 pieces for rebuilding more than 50 types of patio door roller assemblies.</p> <p>Also see individual rollers</p>		
<p>R0029</p> <p>1-1/32" Diameter Nylon with axle and sleeve</p> <p>1-1/32" dia 1/4" hole 1/4" wide 1/4" hub</p>	<p>R0030</p> <p>Nylon with ball bearing metal hub</p> <p>1-1/4" dia 1/4" hole 5/16" wide 3/8" hub</p>	<p>R0187</p> <p>Metal with ball bearing hub</p> <p>1" dia 1/4" hole 9/32" wide 3/8" hub</p>
<p>R0189</p> <p>Metal with ball bearing hub and axle</p> <p>1-1/4" dia 1/4" hole 5/16" wide 3/8" hub</p>	<p>K0016</p> <p>3/4" 2-11/16" 1-5/8" (Adjustable) K0016</p> <p>Bright Chrome Plate Over Die Cast Zinc</p>	<p>K0046</p> <p>9/16" 1-15/16" 1/2"</p>
<p>K0066</p> <p>1-5/8" (Adjustable) 2-25/32" 7/8"</p> <p>Bright Chrome Plate Over Die Cast Zinc K0066 CROSSLY</p>	<p>K-122</p> <p>2-3/4" 3/4"</p>	<p>Don't see what you need? We have more than 40,000 parts available. Please send a sample, for proper identification, to our Research Department at 1644 N. Mannheim Rd., Stone Park, IL 60165</p>

BLAINE SERVICE & SUPPLY

PATIO DOOR KEEPERS / ROLLER ASSEMBLIES

<p>K0089</p>	<p>K0094</p> <p>Die Cast</p>	<p>K0130</p> <p>Die Cast Zinc</p>
<p>K0139</p>	<p>The parts featured in this flyer are strictly a representation of more than 40,000 hardware parts available through Blaine. Please contact our Customer Service Department at 1-708-343-8800 for assistance in locating the parts you need.</p>	<h2>Roller Assemblies</h2>
<p>RA0017</p> <p>Stanley</p> <p>1-1/2" Diameter Wheel</p>	<p>RA0024</p> <p>Peachtree Steel Roller</p> <p>1-1/4" dia.</p>	<p>RA0028</p> <p>Steel 1-1/4" Dia. Wheel</p>
<p>RA0030</p> <p>Flare width = 7/8" 1-1/4" dia. (5/16" wide)</p>	<p>RA0038-058 Nylon RA0038-050 Steel</p> <p>Capitol</p> <p>1-1/4" Dia. Wheel</p>	<p>RA0049</p> <p>Northrop</p> <p>1-1/2" Dia. Wheel</p>
<p>RA0100-058 Nylon RA0100-050 Steel</p> <p>1-1/2" o.d. Fleetwood, Fullview & Others</p>	<p>RA0113-050 Steel Roller</p>	<p>RA0142</p> <p>Arcadia</p> <p>Nylon Wheel 1-11/16" Diameter</p>

BLAINE SERVICE & SUPPLY

PATIO DOOR ROLLER ASSEMBLIES

<p>RA0148</p> <p>Ador / Hillite 11/16" 1-3/8" 1-11/16" 1-1/2" Diameter Nylon Wheel</p>	<p>RA0163</p> <p>9/16" 7/8" dia.</p> <p>UNAVAILABLE</p> <p>Replaces Unavailable RA-54, Shown Above Steel Roller</p>	<p>RA0215</p> <p>Window Master 3/4" 1-3/8" 2-1/8" 1-1/4" Diameter Steel Wheel</p>
<p>RA0216</p> <p>15/16" 2-1/16" Steel Wheel 1-1/4" Diameter</p>	<p>RA0244</p> <p>1-1/8" 1-3/4" Steel Wheel 1-1/4" Diameter</p>	<p>RA0254 Steel Roller</p> <p>23/32" 2-5/16" 1-1/4" 1-1/8" dia (5/16" width) Dimple width - 7/8"</p>
<p>RA0286 Various Mfrs.</p> <p>3-1/8" 1-1/8" dia. 1-1/16" 3/4"</p> <p>Steel Tandem Ball Bearing Rollers</p>	<p>RA0311-3'-Kit-040 RA0311-4'-Kit-040</p> <p>Dual Roller Assembly Shown Replaces Original Die Cast Roller Assemblies on New Units</p> <p>RA0311-4'-Kit-Rebuild</p>	
<p>RA0291 Steel Roller</p> <p>7/8" 1-13/16" 4-1/2" 1-1/2" dia. 1-1/2" dia.</p>	<p>RA0313 Steel Roller Flat Tread</p> <p>1" roller</p> <p>1-3/64" 1/2" C-C 1-3/4" 39/64"</p>	<p>RA0335 Steel Roller</p> <p>15/16" 1-1/8" 9/16" 1-1/16" dia.</p>
<p>RA0337</p> <p>Used By Several Patio Door Manufacturers</p> <p>53/64" 1-5/8" 2-3/16" 1-1/2" Diameter Steel Wheel</p>	<p>RA0341 Andersen</p> <p>1-3/4" 4-1/16"</p>	<p>RA0342</p> <p>Noranda Building Three Rivers Aluminum Bee Cee</p> <p>3/4" 1-1/8" 1-11/16" 1-1/4" Diameter Steel Wheel</p>





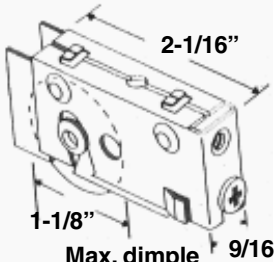
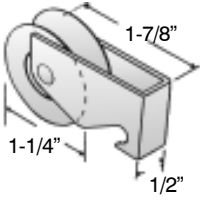
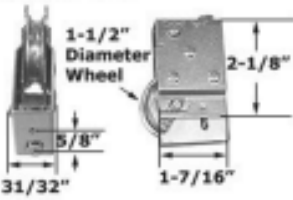
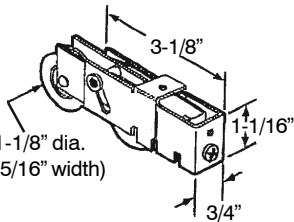
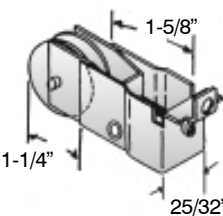
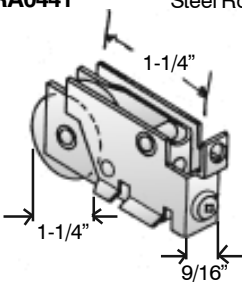
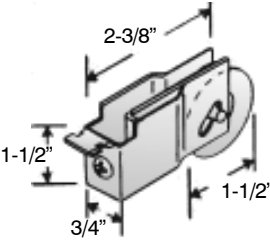
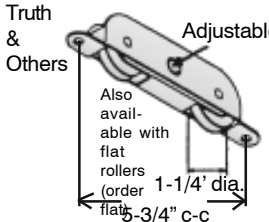
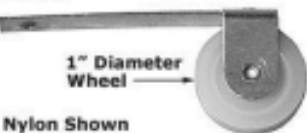

BLAINE SERVICE & SUPPLY

PATIO DOOR ROLLER ASSEMBLIES

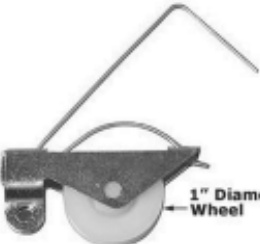
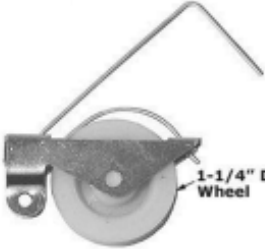
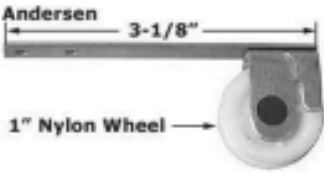
<p>RA0414</p>  <p>2-1/16" 1-1/8" Max. dimple width: 21/32"</p>	<p>RA0419 Silverline Steel Roller</p>  <p>1-7/8" 1-1/4" 1/2"</p>	<p>RA0430</p>  <p>1-1/2" Diameter Wheel 2-1/8" 5/8" 31/32" 1-7/16"</p>
<p>RA0431 order RA0286, shown here</p>  <p>3-1/8" 1-1/8" dia. (5/16" width) 1-1/16" 3/4"</p>	<p>RA-438 Steel Roller</p>  <p>1-5/8" 1-1/4" 25/32"</p>	<p>RA0441 Steel Roller</p>  <p>1-1/4" 1-1/4" 9/16"</p>
<p>This catalog represents a small sample of more than 40,000+ parts available through Blaine. If you do not see the part you need, please contact our Customer Service Department, at 708-343-8800, for indepth assistance!</p>	<p>RA0483 Nylon Roller</p>  <p>2-3/8" 1-1/2" 3/4" 1-1/2"</p>	<p>39.10.00.203 Steel 39.11.00. Nylon</p>  <p>Truth & Others Adjustable Also available with flat rollers (order 1-1/4" dia. flat, 5-3/4" c-c)</p>
	<p>PATIO DOOR GUIDES</p>	
<p>G0047</p>  <p>1" Diameter Wheel Nylon Shown For Steel, Order G0047-050 For Nylon Ball Bearing Roller, Order G0047-BB-058</p>		

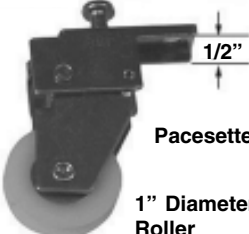
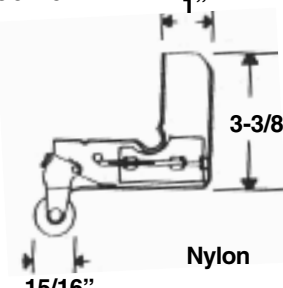
BLAINE SERVICE & SUPPLY

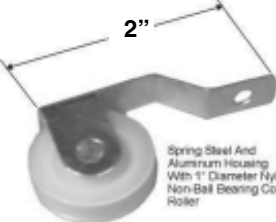
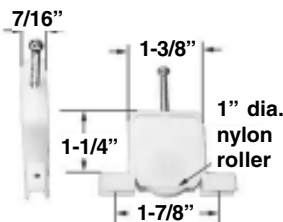
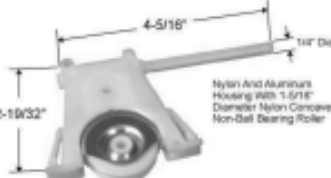
PATIO DOOR GUIDES

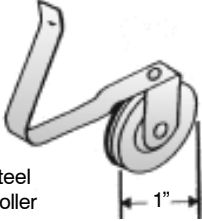
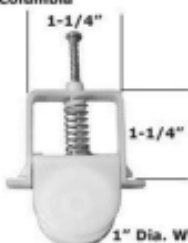
<p>G0152-058 Nylon G0152-050 Steel</p> 	<p>G0155-058 Nylon G0155-050 Steel</p>  <p>1" Diameter Wheel</p>	<p>G0167</p>  <p>1-1/4" Dia Wheel</p>
<p>G0171</p>  <p>Andersen 3-1/8"</p> <p>1" Nylon Wheel</p>	<p>G0176-058 Nylon G0176-050 Steel</p> <p>Columbia</p>  <p>3/8"</p> <p>1-3/4"</p>	<p>G0205-058 Nylon G0205-050 Steel</p>  <p>1/2"</p> <p>Pacesetter</p> <p>1" Diameter Roller</p>
<p>G0226</p>  <p>1"</p> <p>3-3/8"</p> <p>15/16"</p> <p>Nylon</p>	<p>G0236</p>  <p>1-51/64"</p> <p>1-15/16"</p> <p>White Nylon And Aluminum 2 pc. Housing With 1" Diameter Nylon Concave Non-Ball Bearing Roller</p>	<p>G0238-058 Nylon G0238-05 Steel G0238-BB-058</p>  <p>2"</p> <p>Spring Steel And Aluminum Housing With 1" Diameter Nylon Non-Ball Bearing Concave Roller</p>
<p>G0246</p>  <p>7/16"</p> <p>1-3/8"</p> <p>1-1/4"</p> <p>1-7/8"</p> <p>1" dia. nylon roller</p> <p>White Nylon 2 pc housing concave ball bearing roller</p>	<p>G0251 Andersen</p>  <p>4-5/16"</p> <p>2-19/32"</p> <p>1/4" Dia</p> <p>Nylon And Aluminum Housing With 1-5/16" Diameter Nylon Concave Non-Ball Bearing Roller</p>	<p>G0252 Andersen</p>  <p>1-1/4" Diameter Nylon Wheel</p>
<p>G0257 Columbia</p>  <p>15/16" Diameter Nylon Wheel</p>	<p>G-262 Various Manufacturers</p>  <p>Steel Roller</p> <p>1"</p>	<p>G0268-058 Nylon G0267-050 Steel</p> <p>Columbia</p>  <p>1-1/4"</p> <p>1-1/4"</p> <p>1" Dia. Wheel</p>

BLAINE SERVICE & SUPPLY

TOILET PARTITIONS & HARDWARE

TYPES OF MATERIALS AVAILABLE:

- Plastic Laminate with Solid Phenolic Core
- Plastic Laminate Bonded to Solid Particle Board
- Solid Plastic
- Stainless Steel
- Baked Enamel on Steel

Toilet Partition Brochures with color charts available upon request. Please contact our Customer Service Department for assistance.

3510 Top Hinge

99109 Top Hinge Pin

9173 Tamper Proof Screw

2150* Headrail Wall Bracket

1750-1** - For panels
1830-1 1/4** - For pilasters

Single Ear Wall Brackets Also Available. Order 1760-1" or 1840-1-1/4"

63060 Top Hinge Assembly (PL)

5510 Keeper & Door Strike

6670 Headrail End Plug

6660 Headrail End Plug (PL)

5110 Keeper & Door Strike (PL)

5050 Slide Latch (PL)

6140 Concealed Latch & Emergency Cover

9151* Shoe Clip

63090 Bottom Hinge

63030 Bottom Hinge Assembly (PL)

9149 Pilaster Shoe (Specify Size)

9149-PL Pilaster Shoe (Specify Size) (PL)

9150* Floor Bracket

GRAB BAR APPLICATIONS

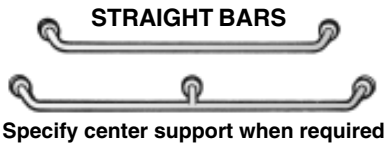

BAR NUMBER LENGTH

BAR NUMBER	LENGTH
NUMBER 10	12"
NUMBER 11	16"
NUMBER 12	18"
NUMBER 13	24"
NUMBER 14	32"
NUMBER 15	42"
NUMBER 16	36"
NUMBER 17	48"

FLANGE SPECIFICATIONS

*Snap-on flange also available.	ROUND	CONCEALED
	<p>Bolt Hole Circle 2-1/4"</p>	<p>Three 1/4-20 set screws in lip</p>
TUBE DIAMETER		
1"	100E	100C
1-1/4"	125E	125C
1-1/2"	150E	150C

This is a representation of the grab bars available through Blaine. Please contact our Customer Service Department for detailed literature and assistance.

BLAINE SERVICE & SUPPLY

TOILET PARTITIONS / ENTRY & URINAL SCREENS

DOORS

Stock Number

- TPDR9100
- TPDR9101
- TPDR9102
- TPDR9103
- TPDR9104
- TPDR9105
- TPDR9106
- TPDR9107



- 21-5/8" w x 58" h Door
- 23-5/8" w x 58" h Door
- 25-5/8" w x 58" h Door
- 27-5/8" w x 58" h Door
- 29-5/8" w x 58" h Door
- 31-5/8" w x 58" h Door
- 33-5/8" w x 58" h Door
- 35-5/8" w x 58" h Door

PANELS

- TPPL9108
- TPPL9109
- TPPL9110
- TPPL9111
- TPPL9112
- TPPL9113
- TPPL9114
- TPPL9115
- TPPL9116
- TPPL9117
- TPPL9118
- TPPL9119
- TPPL9120
- TPPL9121
- TPPL9122
- TPPL9173
- TPPL9174



- 15-1/2" w x 58" h Panel
- 17-1/2" w x 58" h Panel
- 21-1/2" w x 58" h Panel
- 23-1/2" w x 58" h Panel
- 25-1/2" w x 58" h Panel
- 27-1/2" w x 58" h Panel
- 29-1/2" w x 58" h Panel
- 31-1/2" w x 58" h Panel
- 33-1/2" w x 58" h Panel
- 35-1/2" w x 58" h Panel
- 37-1/2" w x 58" h Panel
- 39-1/2" w x 58" h Panel
- 45-1/2" w x 58" h Panel
- 51-1/2" w x 58" h Panel
- 54-1/2" w x 58" h Panel
- 57-1/2" w x 58" h Panel
- 69-1/2" w x 58" h Panel

PILASTERS

- TPPR9124
- TPPR9125
- TPPR9126
- TPPR9127
- TPPR9128
- TPPR9129
- TPPR9130
- TPPR9131



- 3" w x 82" h Pilaster
- 4" w x 82" h Pilaster
- 5" w x 82" h Pilaster
- 6" w x 82" h Pilaster
- 7" w x 82" h Pilaster
- 8" w x 82" h Pilaster
- 10" w x 82" h Pilaster
- 12" w x 82" h Pilaster

ALUMINUM HEADRAILS

- TPAH9134
- TPAH9135
- TPAH9136
- TPAH9137
- TPAH9138
- TPAH9139
- TPAH9140
- TPAH9142

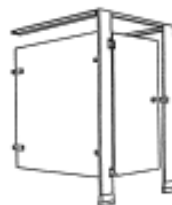

- 37" L Aluminum Headrail
- 56" L Aluminum Headrail
- 66" L Aluminum Headrail
- 70" L Aluminum Headrail
- 72" L Aluminum Headrail
- 74" L Aluminum Headrail
- 82" L Aluminum Headrail
- 96" L Aluminum Headrail

SCREENS & POSTS

- TPSP9123

6" x 70" h Screen Pilaster-use a 35-1/2"-45-1/2" w panel for pilaster supported urinal screen (sold separately)

- TPUS9132
- TPUS9133

18" w x 42" h bracket supported screen
24" w x 42" h bracket supported screen

Doors, panels, pilasters and urinal screens - specify steel by adding 050 to the end of the stock number or plastic laminate by adding 058. Aluminum headrail - specify 040 for use on steel pilasters or PL-040 for use on plastic laminate pilasters.

Complete with mounting hardware

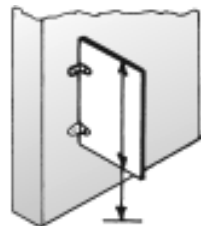

Bracket Supported

Finishes:
Baked enamel on steel and high pressure plastic laminate.

Sizes:
18" w x 42" h
24" w x 42" h

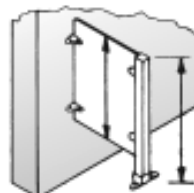

Post Supported Finishes:
Baked enamel on steel and high pressure plastic laminate.

Panel Sizes:
15-1/2" x 17-1/2" x 21-1/2",
23-1/2", 25-1/2", 27-1/2",
29-1/2", 31-1/2" and 33-1/2"
wide x 58" high

Aluminum Post:
1-3/4" x 1-3/4" x 70" high

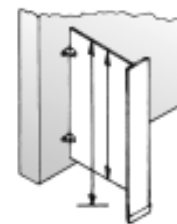

Pilaster Supported

Finishes:
Baked enamel on steel and high pressure plastic laminate.

Panel Sizes:
35-1/2", 37-1/2", 39-1/2"
and
45-1/2" wide x 58" high

Pilaster Size:
6" w x 70" high

BLAINE SERVICE & SUPPLY

TOILET PARTITION HARDWARE

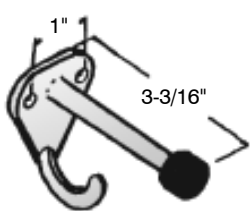
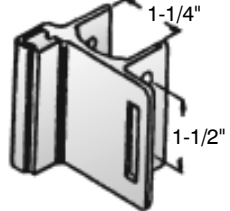
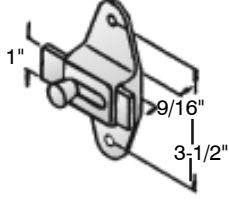
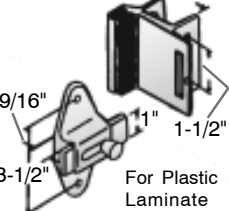
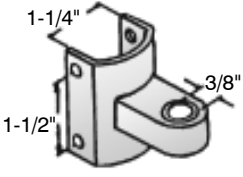
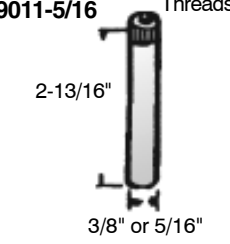
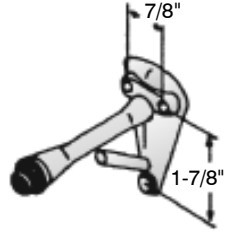
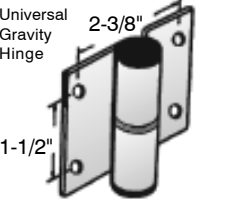
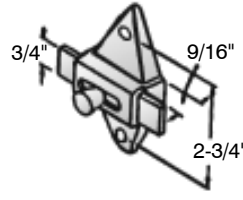
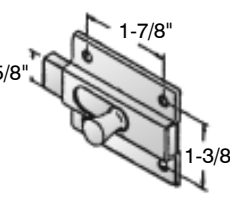
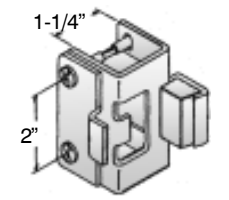
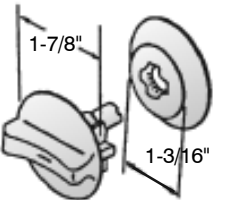
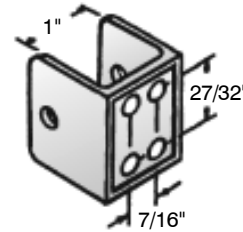
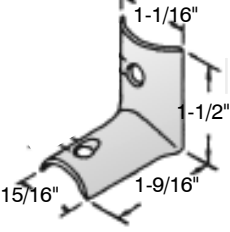
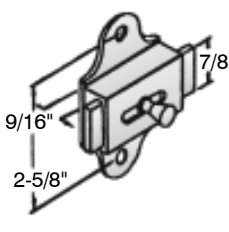
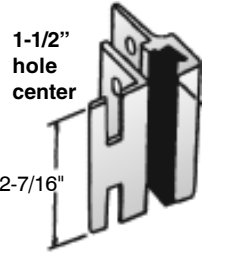
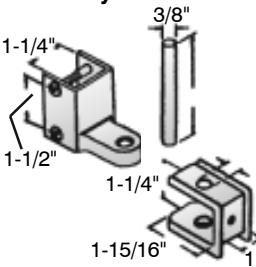
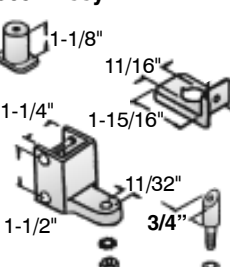
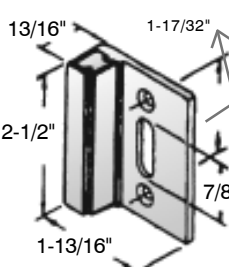
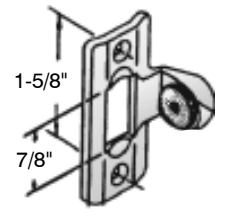
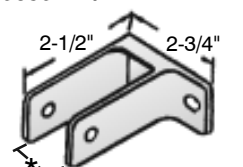
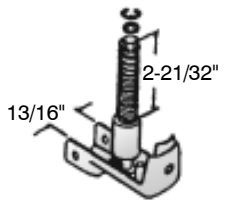
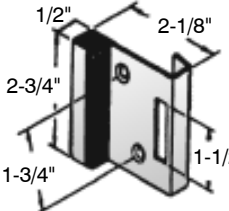
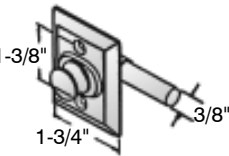
<p>9007</p> 	<p>9008 For Steel Pilasters</p> 	<p>9009</p> 	<p>9009-Assy-PL 1-1/4"</p>  <p>For Plastic Laminate</p>
<p>9010</p> 	<p>9011-3/8 10-24 Threads 9011-5/16</p> 	<p>9013</p> 	<p>9014 Please specify right or left hand</p> <p>Universal Gravity Hinge</p> 
<p>9021</p> 	<p>9023</p> 	<p>9024</p> 	<p>9031</p> 
<p>9038</p> 	<p>9039</p> 	<p>9041</p> 	<p>9045 Two Piece</p> <p>1-1/2" hole center</p> 
<p>9053-Assy</p> 	<p>9054-Assy</p> 	<p>9056</p> 	<p>9057</p> 
<p>9059-3/4" 9059-1" 9059-1-1/4"</p> 	<p>9063</p> 	<p>9070-Spec</p> 	<p>9071</p> 

9100-1/2"
9100-3/4"
9100-1"

Continuous Wall
Bracket

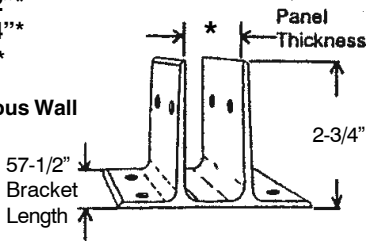

Construction Styles of Toilet Compartments

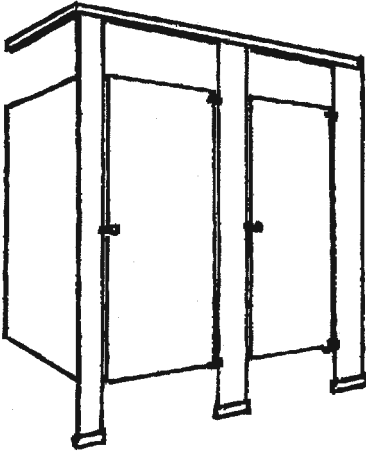

HEADRAIL BRACED (Most Popular)

For easy, economical installations, the headrail braced is a great choice. This unit requires no special floor construction; therefore, it can be used in new or old buildings.

CEILING HUNG

Ceiling hung partitions combine functional styling with an unobstructed floor area which simplifies cleaning and reduces the cost of maintenance.

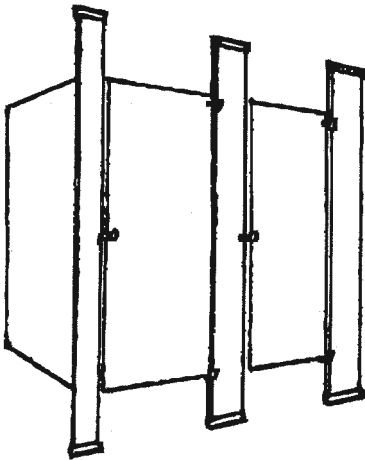
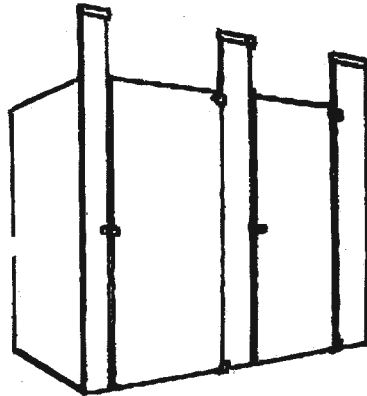

FLOOR TO CEILING

Floor to ceiling is recommended for all areas subject to heavy usage. For problem areas we recommend the use of full length aluminum brackets and hinges.

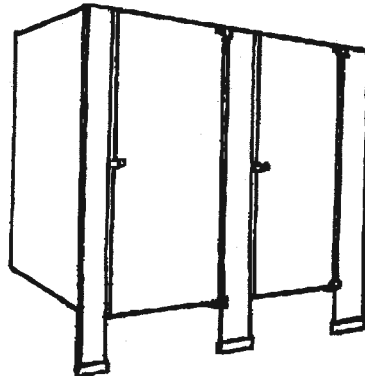

FLOOR SUPPORTED

Floor supported partitions have the same functional lines as ceiling hung partitions without the top structure.

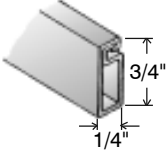
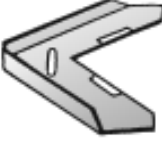

BLAINE SERVICE & SUPPLY

SCREEN FRAME

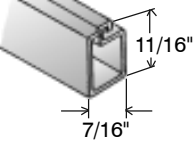
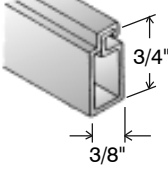
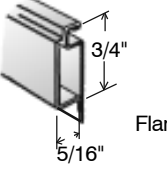
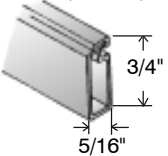
<p>91021 1/4" X 3/4" BOX</p> 	<p>Mitred Corners</p>  <table border="1"> <thead> <tr> <th>Frame No.</th> <th>Corner No.</th> </tr> </thead> <tbody> <tr> <td>91007</td> <td>91007-CR</td> </tr> <tr> <td>91015</td> <td>91015-CR</td> </tr> <tr> <td>91021</td> <td>91021-CR</td> </tr> <tr> <td>91088</td> <td>91088-CR</td> </tr> <tr> <td>91051</td> <td>91007-CR</td> </tr> </tbody> </table>	Frame No.	Corner No.	91007	91007-CR	91015	91015-CR	91021	91021-CR	91088	91088-CR	91051	91007-CR	<p>Non-Mitred Corners</p>  <table border="1"> <thead> <tr> <th>Frame No.</th> <th>Corner No.</th> </tr> </thead> <tbody> <tr> <td>91007</td> <td>91207-CR</td> </tr> <tr> <td>91015</td> <td>91215-CR</td> </tr> <tr> <td>91088</td> <td>91288-CR</td> </tr> <tr> <td>91021</td> <td>91221-CR</td> </tr> </tbody> </table>	Frame No.	Corner No.	91007	91207-CR	91015	91215-CR	91088	91288-CR	91021	91221-CR
Frame No.	Corner No.																							
91007	91007-CR																							
91015	91015-CR																							
91021	91021-CR																							
91088	91088-CR																							
91051	91007-CR																							
Frame No.	Corner No.																							
91007	91207-CR																							
91015	91215-CR																							
91088	91288-CR																							
91021	91221-CR																							
<p>91015 7/16" X 3/4" BOX</p> 	<p>91088 3/8" X 3/4" BOX</p> 	<p>91051 5/16" X 3/4" BOX</p> 																						
<p>91007 5/16" X 3/4" BOX</p> 	<p>Screen frame is sold in 6'3" (75 in.) 8' and 12'6" lengths. Truck delivery required for 12'6" lengths. SS-140 spline recommended for all Blaine screen frame.</p>																							

DRAFT-SEAL WEATHERSTRIPPING

Polypropylene Backing Resists Shrinkage

	A		B		C	
	In	mm	In	mm	In	mm
WS-7	.187	4.7	.150	4.0	.035	0.9
WS-8	.187	4.7	.190	4.0	.035	0.9
WS-9	.187	4.7	.250	6.7	.035	0.9
WS-15	.229	5.9	.260	6.7	.035	0.9
WS-16	.229	5.9	.310	7.9	.035	0.9
WS-20	.270	6.9	.150	4.0	.035	0.9
WS-22	.270	6.9	.170	4.0	.035	0.9
WS-24	.270	6.9	.250	6.5	.035	0.9
WS-25	.270	6.9	.310	7.9	.035	0.9
WS-26	.270	6.9	.360	9.0	.035	0.9



Reduces Air Infiltration
Resists Shrinkage
Exceeds AAMA Specifications

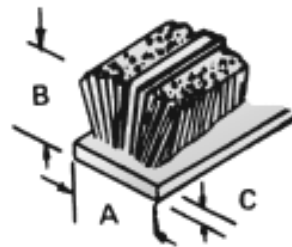

R-200-Kit

Mechanic's Best Helper

The R-200-Kit contains over 160 pieces for rebuilding more than 50 types of patio door roller assemblies.

The kit is organized in a convenient plastic case complete with contents diagram for easy reference.

Also see individual rollers

BLAINE SERVICE & SUPPLY

SCREEN WIRE

Aluminum Screening - 100' Roll		Aluminum Screening - 100' Roll	
Size	Part Number <i>Black or Charcoal</i>	Size	Part Number <i>Brite</i>
20"	SW20-Black/Charcoal-040	20"	SW20-Brite-040
24"	SW24-Black/Charcoal-040	24"	SW24-Brite-040
28"	SW28-Black/Charcoal-040	28"	SW28-Brite-040
30"	SW30-Black/Charcoal-040	30"	SW30-Brite-040
32"	SW32-Black/Charcoal-040	32"	SW32-Brite-040
34"	SW34-Black / Charcoal-040	34"	SW34-Brite-040
36"	SW36-Black / Charcoal-040	36"	SW36-Brite-040
42"	SW42-Black / Charcoal-040	42"	SW42-Brite-040
48"	SW48-Black / Charcoal-040	48"	SW48-Brite-040
60"	SW60-Black / Charcoal-040	60"	SW60-Brite-040
72"	SW72-Black / Charcoal-040	72"	SW72-Brite-040

ALUMINUM & FIBERGLASS MESH SCREEN WIRE

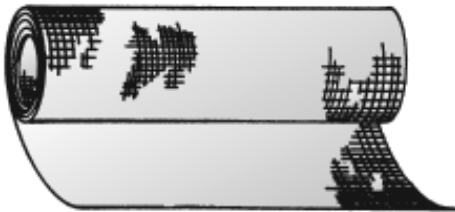

Black Aluminum Screening

- Baked on charcoal finish reduces glare and improves visibility
- Extends life of screening
- 18 X 16 X .011 diameter mesh

Fiberglass Screening

- 18 X 16 X .011 diameter mesh
- Will not dent, corrode or scratch
- Lightweight, yet strong. Easy to install
- Economical alternative to aluminum screening

Aluminum Screening

- 18 X 16 X .011 diameter mesh
- Brite-Kote exclusive dip weld finish
- Free of streaks, lays flat
- Easy to measure and fabricate

Bronze Screening Also Available. Please call Customer Service for details.

Quality Screening By Phifer Wire Products

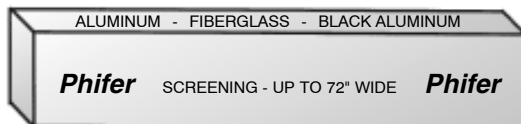

Screen Spline Prices (Available in Gray or Black unless noted-specify when ordering)





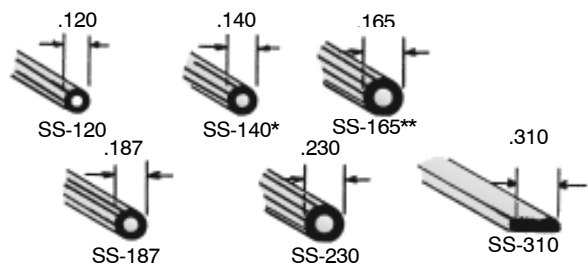





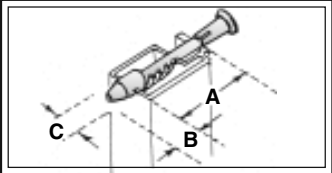
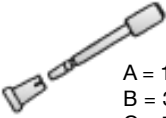
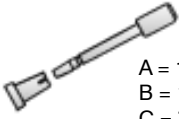

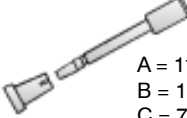
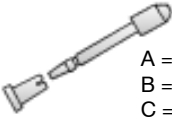

Part Number	Trade Size	Decimel
SS120-062	1/8"	.120
SS140-062	9/64"	.140
SS165-062	11/64"	.165
SS187-062	3/16"	.187
SS230-062	15/64"	.230
SS310-062	5/16"	.312
SS250-062	1/4"	.250

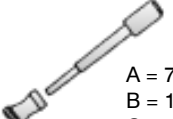
Please Specify Black or Gray

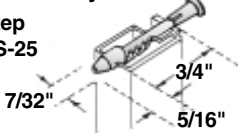
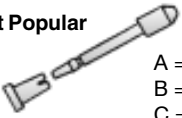

BLAINE SERVICE & SUPPLY

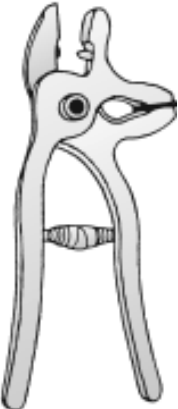
Screen Frame Plungers / Tools / Roller Kit

	<p>2335-058 Nylon</p>  <p>A = 11/16" B = 3/8" C = 7/32"</p>	<p>2336-058 Nylon</p>  <p>A = 11/16" B = 11/32" C = 7/32"</p> <p>w/ black cap</p>
<p>2338-058 Nylon</p>  <p>A = 5/8" B = 11/32" C = 7/32"</p>	<p>2339-058 Nylon</p>  <p>A = 1" B = 1/4" C = 11/32" D = Tapered</p>	<p>2340-058 Metal w/ nylon knob</p>  <p>A = 11/16" B = 11/32" C = 3/16"</p>
<p>2342-040 Metal</p>  <p>A = 9/16" B = 5/16" C = 1/8"</p>	<p>2343-040 Metal w/ nylon knob</p>  <p>A = 11/16" B = 11/32" C = 7/32"</p>	<p>2344-058 Nylon</p>  <p>A = 5/8" B = 11/32" C = 7/32"</p>
<p>2346-040 Metal</p>  <p>A = 7/8" B = 13/32" C = 7/32"</p>	<p>2347-040 Metal</p>  <p>A = 7/8" B = 13/32" C = 3/16"</p>	<p>2348-040 Metal</p>  <p>A = 23/32" B = 3/8" C = 7/32"</p>
<p>2350-040 Metal</p>  <p>A = 19/32" B = 3/8" C = 3/16"</p>	<p>2351-058 Nylon</p>  <p>For 7/16" x 1" frames</p>	<p>1125 Nylon</p> <p>Use Step Drill #S-25</p>  <p>7/32" 3/4" 5/16"</p>
<p>1125-058 Nylon</p> <p>Most Popular</p>  <p>A = 3/4" B = 11/32" C = 7/32"</p> <p>Specify Black or white</p>	<p>2341-040 Metal</p>  <p>A = 5/8" B = 13/32" C = 5/32"</p>	<p>2345-040 Metal</p>  <p>A = 5/8" B = 13/32" C = 7/32"</p>
<p>S-9 Storm Window Tool</p> <p>SPREADER * STRAIGHTENER * CRIMPER</p>  <p>Quickly spreads corners of frames for removal of old tilt keys and corner keys. Provides fast and effective crimping of storm window and screen frame corners. Centered steel dowel dimples frame to hold corners tight. Oil hardened replaceable jaw plates. Flat jaws provide ideal surface for straightening. Cast iron construction.</p>		<p>S-30 "ELIMINATOR"</p> <p>GLASS CALIPER</p>  <p>Specifically designed to eliminate errors during insulating glass unit fabrication. The "Eliminator" makes it easy to measure insulated glass thicknesses up to 1-3/4" in sliding windows and doors. Complete with embossed scale on both sides of caliper. Opens to a wide 7" to fit around almost any frame. Plated stamped steel construction. Comes in a durable, foam padded polypropylene carrying case.</p>





**WE ARE CHICAGOLAND'S
LEADER IN REPLACEMENT
WINDOW & DOOR HARDWARE
WITH MORE THAN 40,000 PARTS
AVAILABLE!**











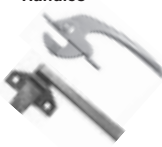





708-343-8800

Fax: (855) 898-6471

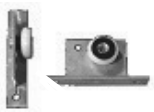
www.buyblaine.com

BLAINE
SERVICE AND SUPPLY
1644 N. Mannheim Rd., Stone Park, IL 60165

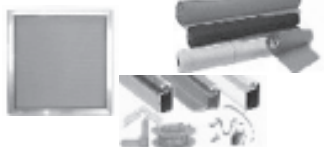
Tube & Channel Balances 	Tape Balances 
Patio Door Parts 	Sash Pulleys 

Gears 	Locking & Cam Handles 	Window Latches 	Antique Handles 	Window Operators 	
S-9 Glass Saver  Storm Window Tool	Crank Handles 	Toilet Partitions & Hardware 	Install-A-Locks 	S-31 Glass Caliper 	Chair Glides 
Security Hardware 	Locker Parts 	Shower Hardware 	Door Closers 	Vent Arms & Hinge Assemblies 	Push Bars 
Keepers 	Pressure Shoes 	Complete Screen Service 		Closet Door Parts 	

1644 N. Mannheim Rd., Stone Park, IL 60185